

X30 WATERSWIFT 60CC - TAG

		FEATURES - CARACTERISTIQUES	
		Cylinder volume <i>Volume du cylindre</i>	59.17 cm ³ (60.00 cm ³ max)
		Bore <i>Alésage</i>	41.81 mm
		Max. bore <i>Alésage max.</i>	42.10 mm
		Max. Stroke <i>Course max.</i>	43.15 mm
		Cooling system <i>Système de refroidissement</i>	Water <i>Eau</i>
		Inlet system <i>Système d'admission</i>	Piston valve <i>Jupe de piston</i>
		Number of carbs <i>Nombre de carburateurs</i>	1
Tillotson Carburettor <i>Carburateur Tillotson</i>	HW-31A (Venturi Ø17)	Cylinder / crankcase transfers n° <i>N° de canaux cylindre / carter</i>	2
Number of piston rings <i>Nombre de segments</i>	1	Inlet / exhaust ports number <i>N° lumières admiss / échapp.</i>	1 / 1
Big end conrod bearing diam. <i>Diamètre palier tête de bielle</i>	18x24x15	Combustion chamber shape <i>Forme chambre de combustion</i>	Spherical <i>Sphérique</i>
Crankshaft ball-bearing diam. <i>Diamètre palier du vilebrequin</i>	20x47x14	Selettra ignition (adjustable) <i>Allumage Selettra (réglable)</i>	2 poles 2 pôles
Small end conr. bearing diam. <i>Diamètre palier pied de bielle</i>	12x16x16	Distance between Conrod centres <i>Longueur (entre axe) de la bielle</i>	88 mm

CYLINDER DEVELOPMENT – DEVELOPPEMENT DU CYLINDRE

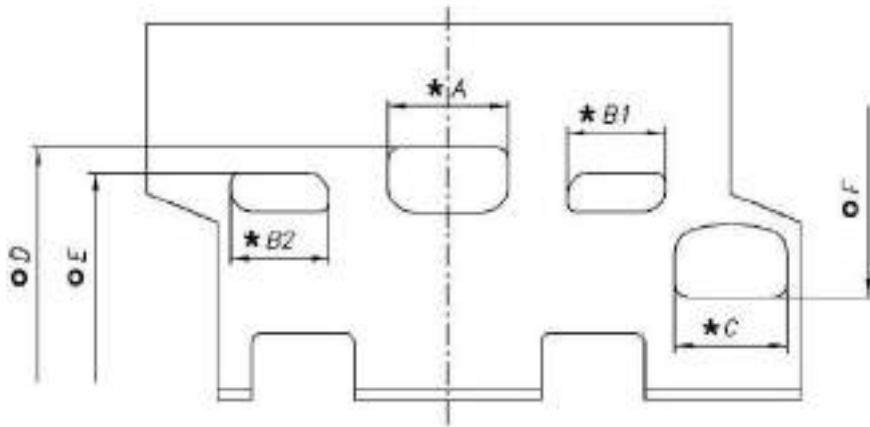

A	28±0.2 mm
B1 = B2	21.8±0.2 mm
C	26±0.2 mm
D	157° max
E	116° ±2°
F	145° max

CHORDAL READING – LECTURE CORDALE

ANGULAR READING BY INSERT A 0.2 mm x 5 mm GAUGE –
LECTURE ANGULAIRE PAR INSERTION D'UNE CALE DE 0.2 mm x 5 mm

USING IAME TOOL Cod. 10194 – *UTILISER OUTIL*

CYLINDER BASE VIEW VUE DE LA BASE DU CYLINDRE

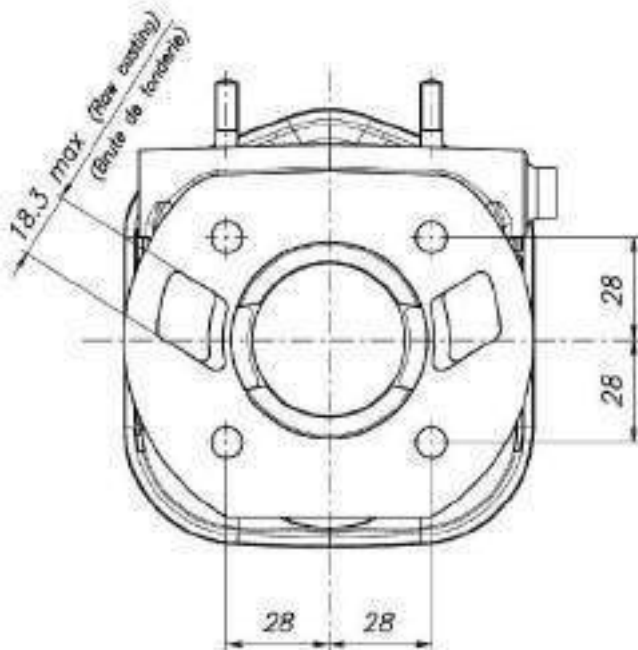

CYLINDER SECTION VIEW VUE EN SECTION DU CYLINDRE

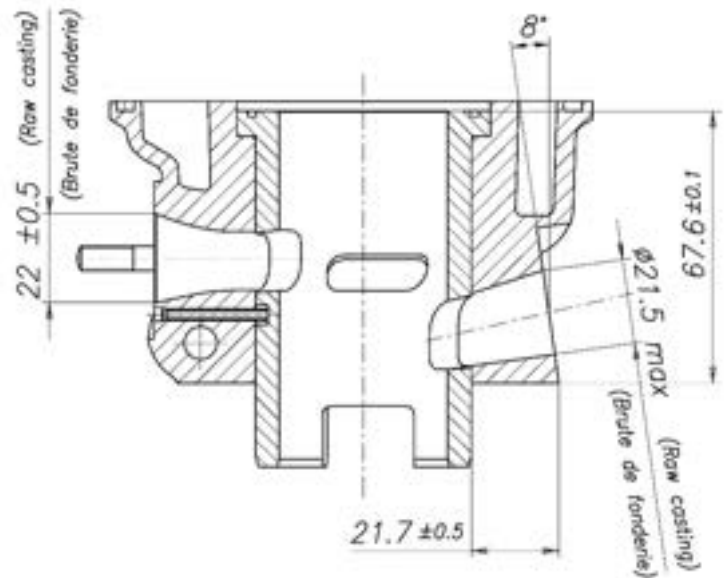

COMBUSTION CHAMBER VIEW
VUE DE LA CHAMBRE DE COMBUSTION

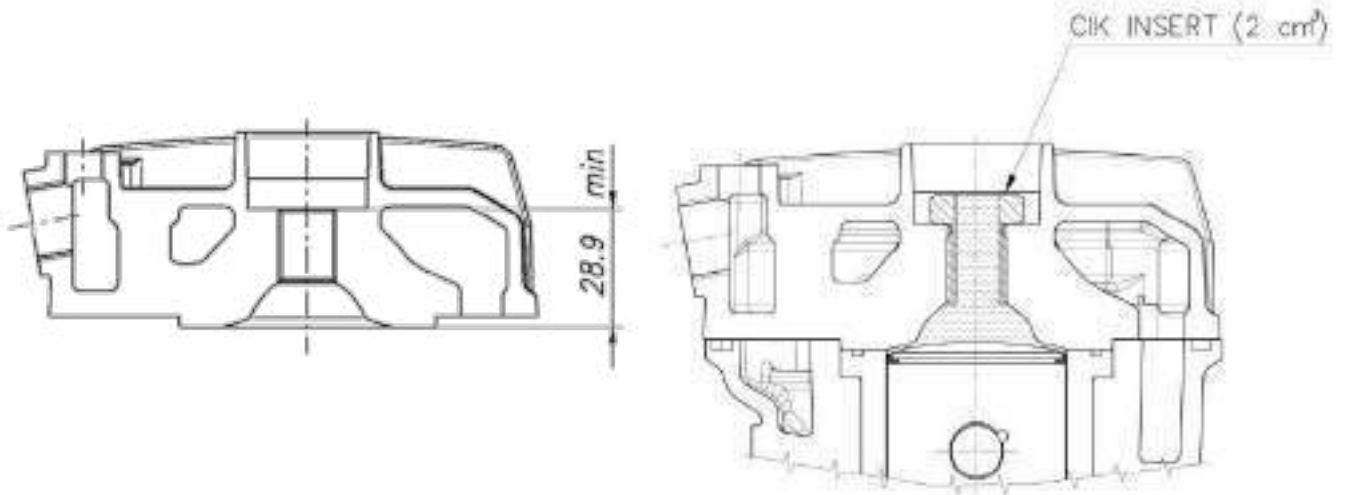

COMBUSTION CHAMBER VOLUME = 6.5 cm³ min.
VOLUME CHAMBRE COMBUSTION

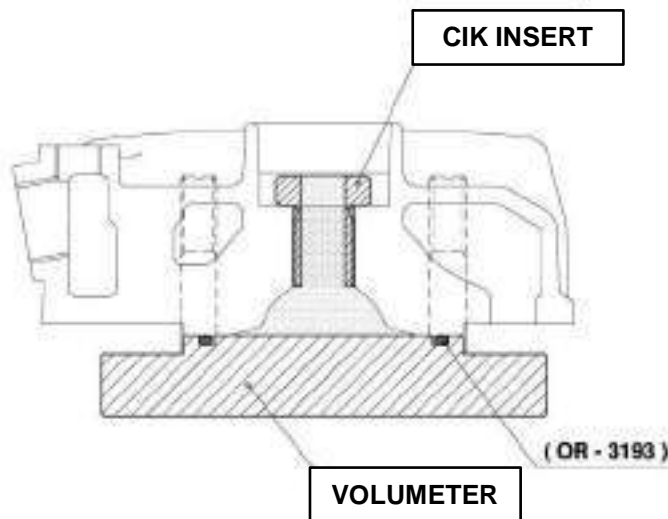

MIN. TOT. VOLUME OF CHAMBER IN THE CYLINDER HEAD = 7.4 cm³
VOLUME MIN. CHAMBRE DE COMBUSTION DANS LA CULASSE

REAR VIEW AND DIMENSION
ARRIERE VUE ET DIMENSION

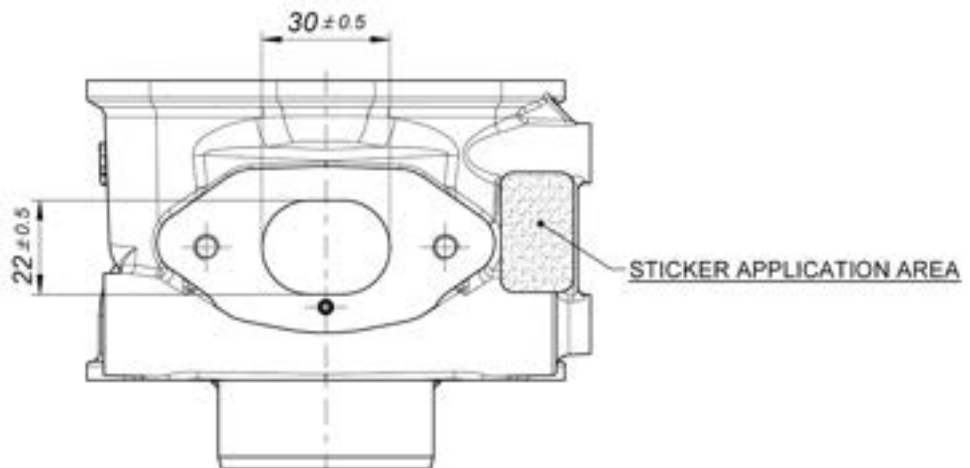

CRANKCASE INSIDE VIEW
VUE A L'INTERIEUR DU CARTER

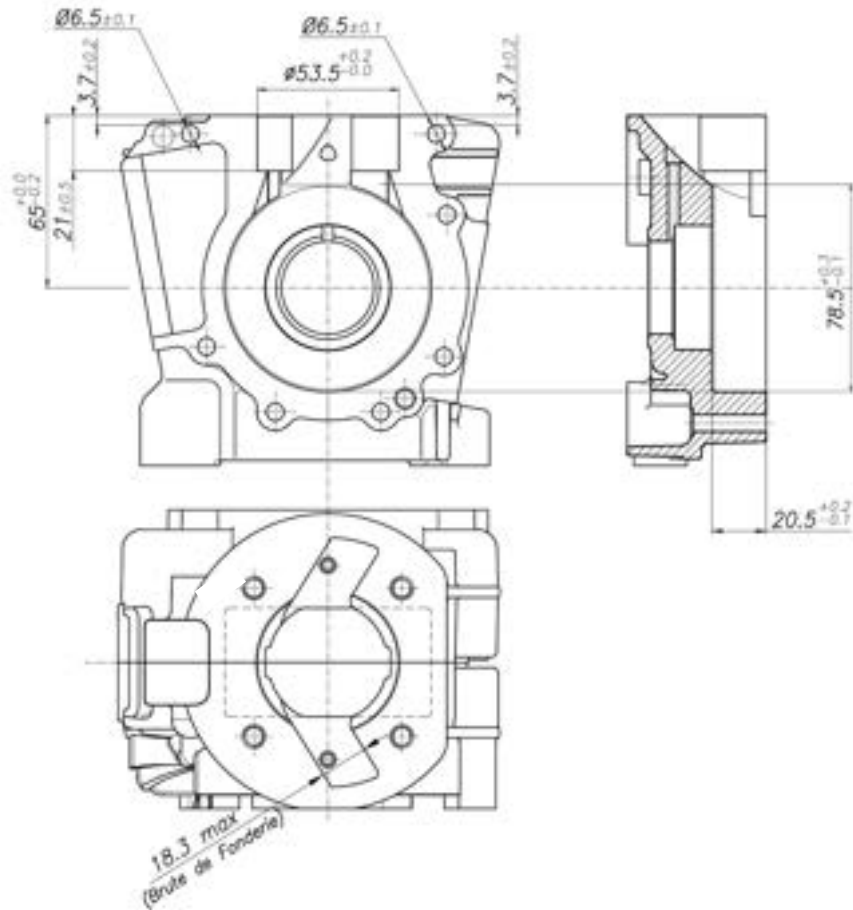

VENTURI CARB. DIMENSIONS and THERMAL SPACERS
CARBURATEUR ET SONS ENTRETOISES

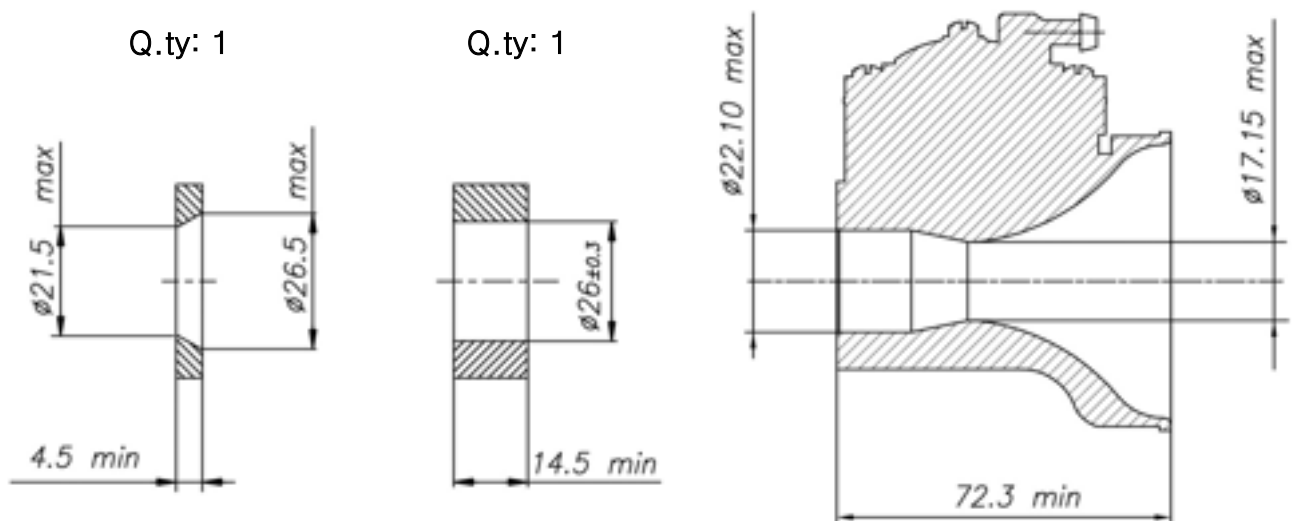

TILLOTSON MOD. HW-31A

DESCRIPTION OF THE CLUTCH – DESCRIPTION DE L'EMBRAYAGE

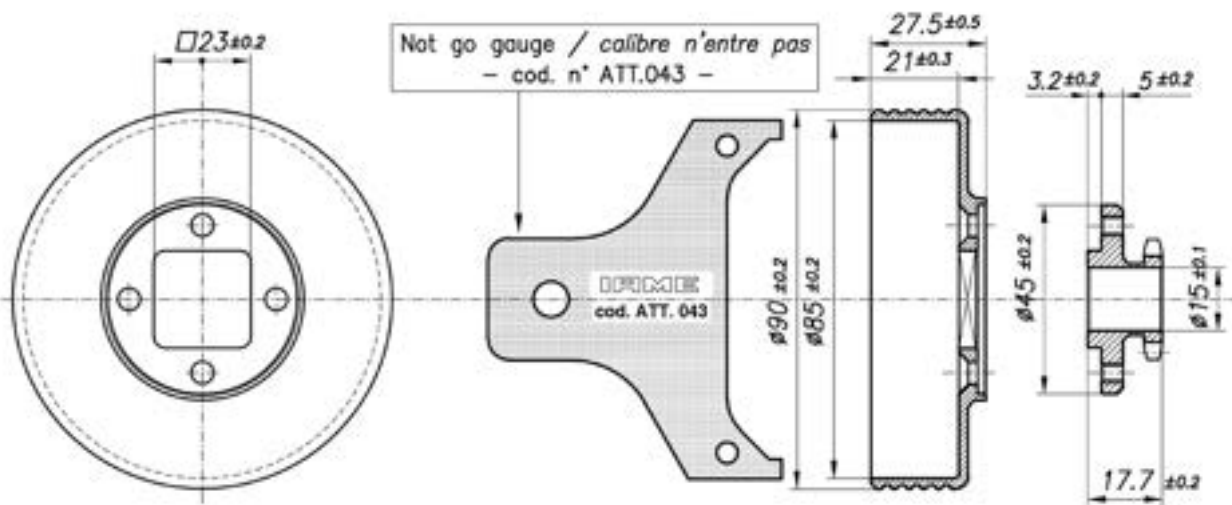
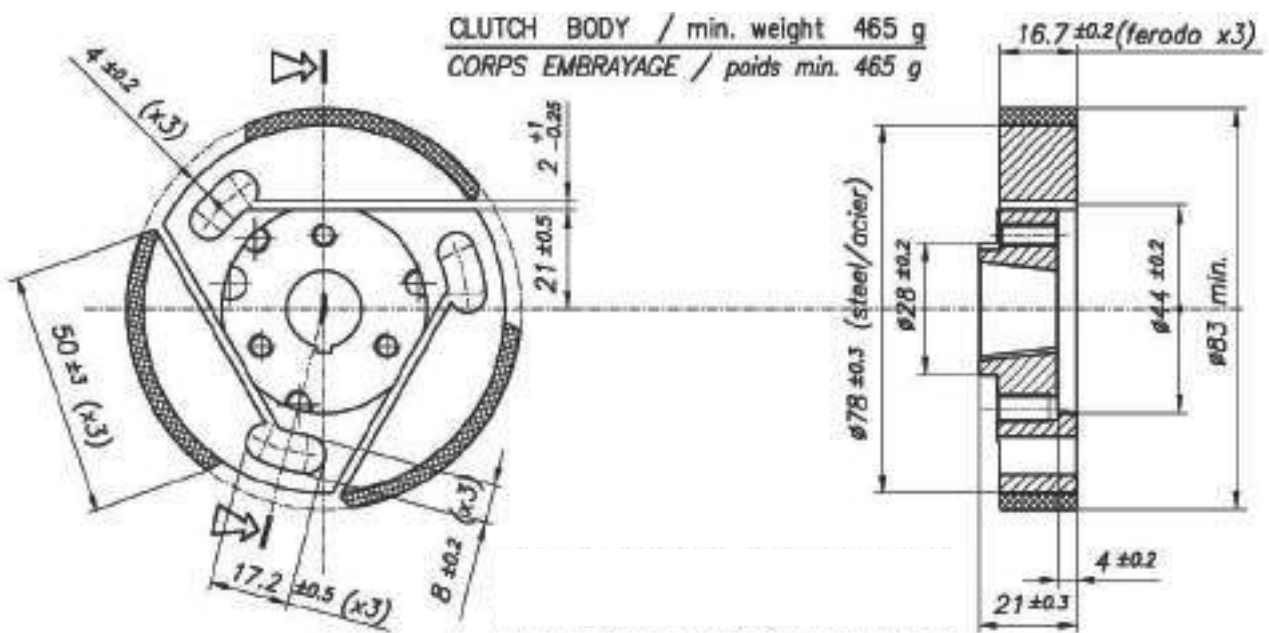
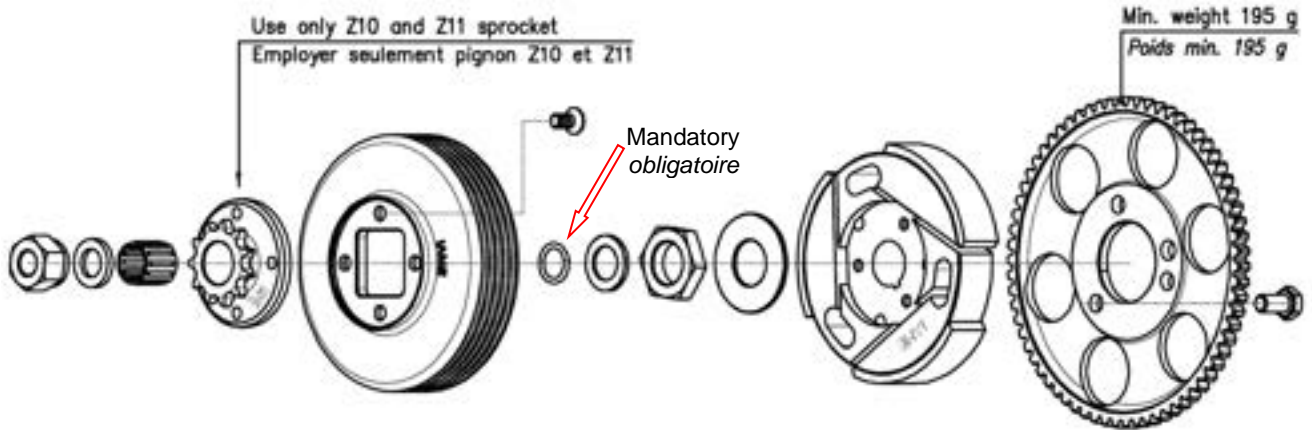

CLUTCH DRUM / min. weight 175 g
CLOCHE D'EMBRAYAGE / poids min. 175 g

DRIVE SPROCKET / min. weight 68 g
PIGNON / poids min. 68 g

ALTERNATIVE EXHAUST MUFFLER with embossed logo
ECHAPPEMENT ALTERNATIVE avec logo en relief



MARKING / MARQUAGE

**Plug for
temperature
probe**
*Connecteur
pour sonde de
température*

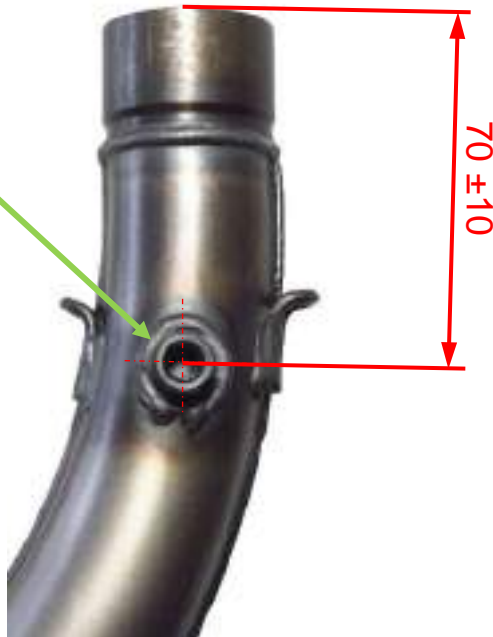

EXHAUST MANIFOLD
RACCORD D'ÉCHAPPEMENT

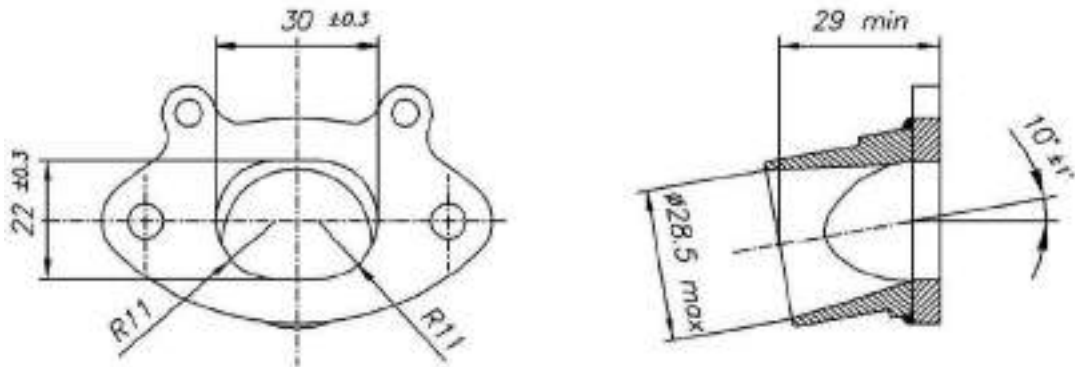

EXHAUST MANIFOLDS WITH RESTRICTED
RACCORDS AVEC RECSTRICTEUR D'ÉCHAPPEMENT

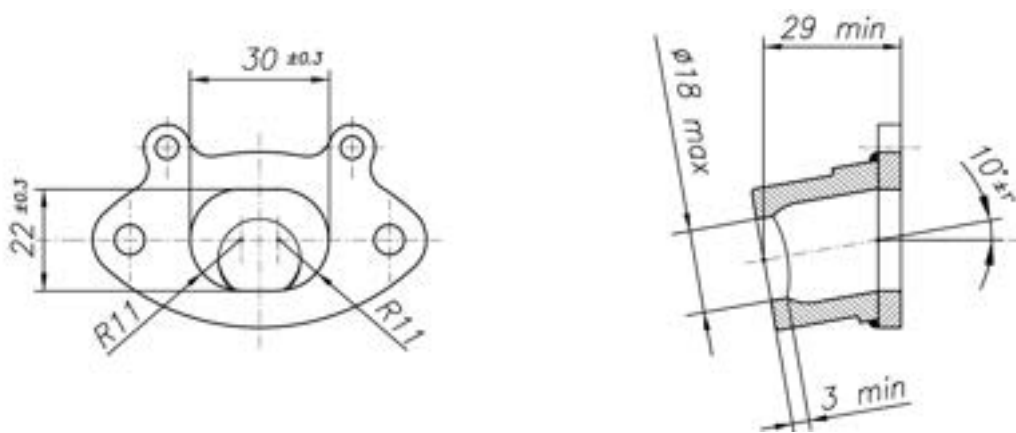
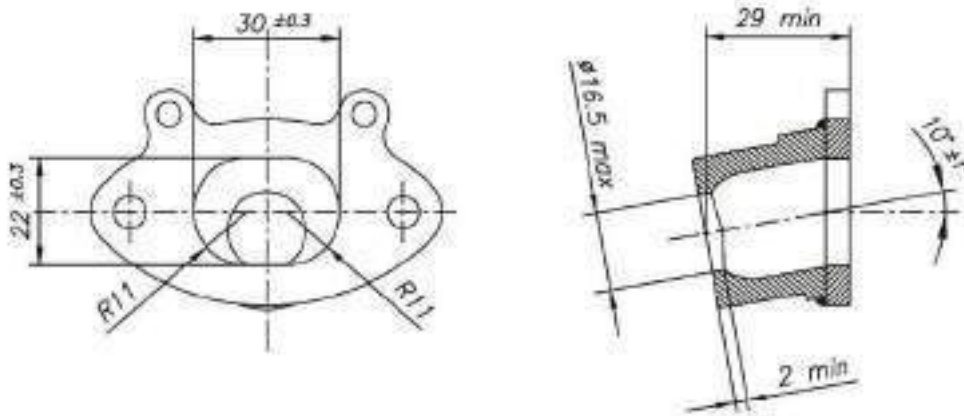

INLET SILENCER – SILENCIEUX D'ASPIRATION

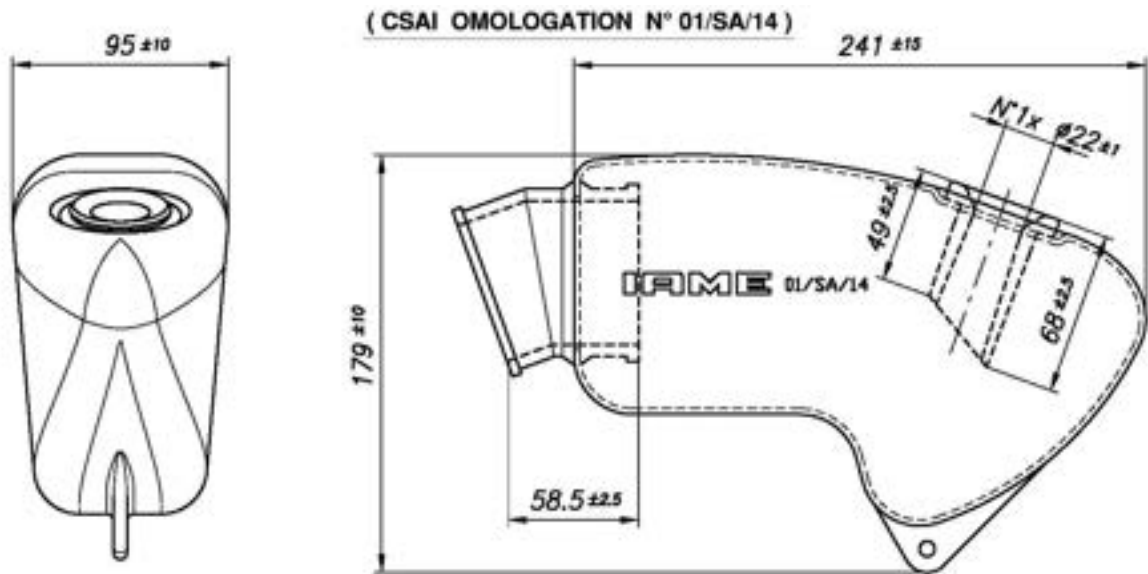

ALTERNATIVE
MANIFOLD WITH SPONGE FILTER
COLLECTEUR AVEC UNE EPONGE
FILTRE

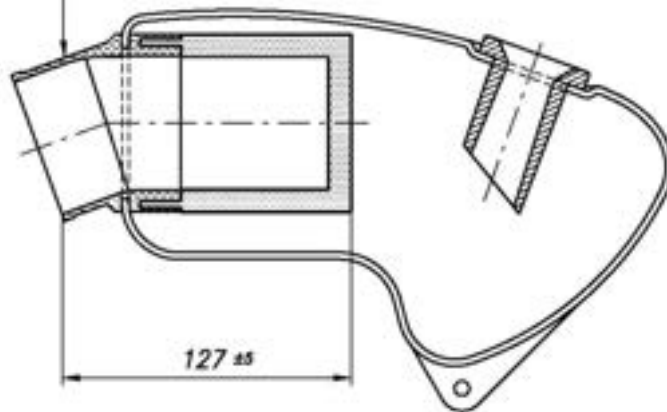

INLET SILENCER - PHOTO PHOTO - SILENCIEUX D'ASPIRATION



WIRING DIAGRAM
SCHÉMA CIRCUIT ÉLECTRIQUE

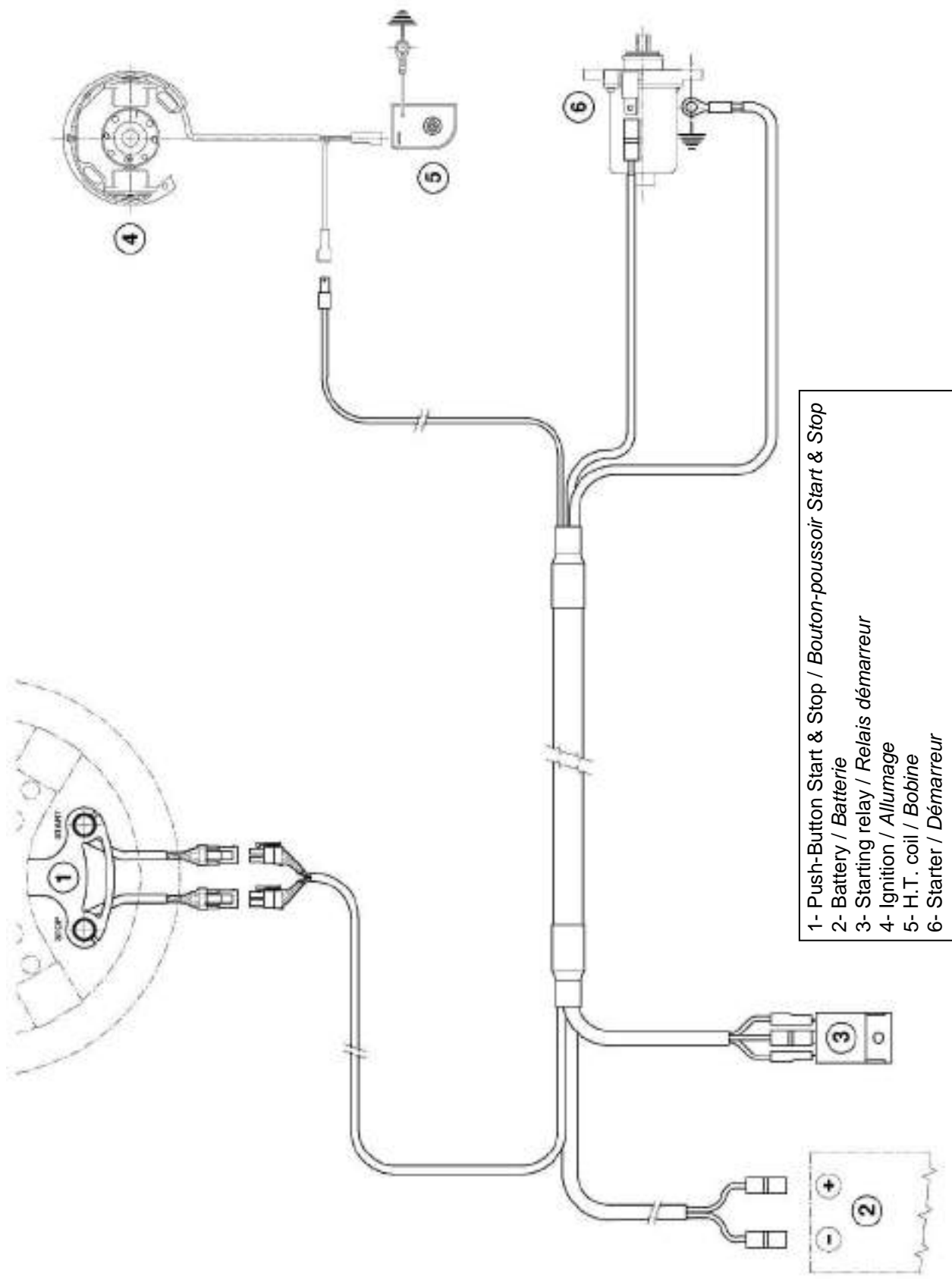

- 1- Push-Button Start & Stop / Bouton-poussoir Start & Stop
- 2- Battery / Batterie
- 3- Starting relay / Relais démarreur
- 4- Ignition / Allumage
- 5- H.T. coil / Bobine
- 6- Starter / Démarreur

PHOTO COMPLETE WIRING
PHOTO DU CÂBLAGE ÉLECTRIQUE COMPLÈTE

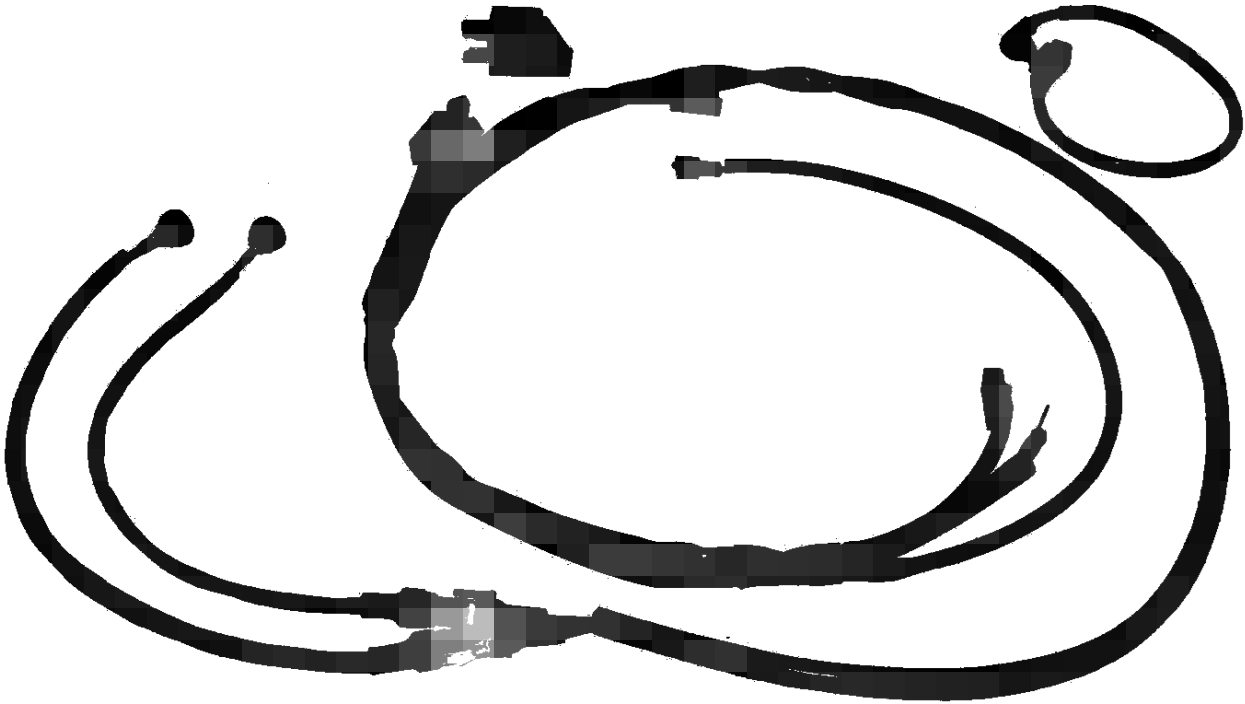

PHOTO IGNITION / PHOTO H.T. COIL (SELETTRA ANALOGUE 2 POLES)
PHOTO ALLUMAGE / PHOTO BOBINE (SELETTRA ANALOGIQUE 2 POLES)



ALTERNATIVE WIRING LOOM DIAGRAM
SCHÉMA CIRCUIT ÉLECTRIQUE ALTERNATIF

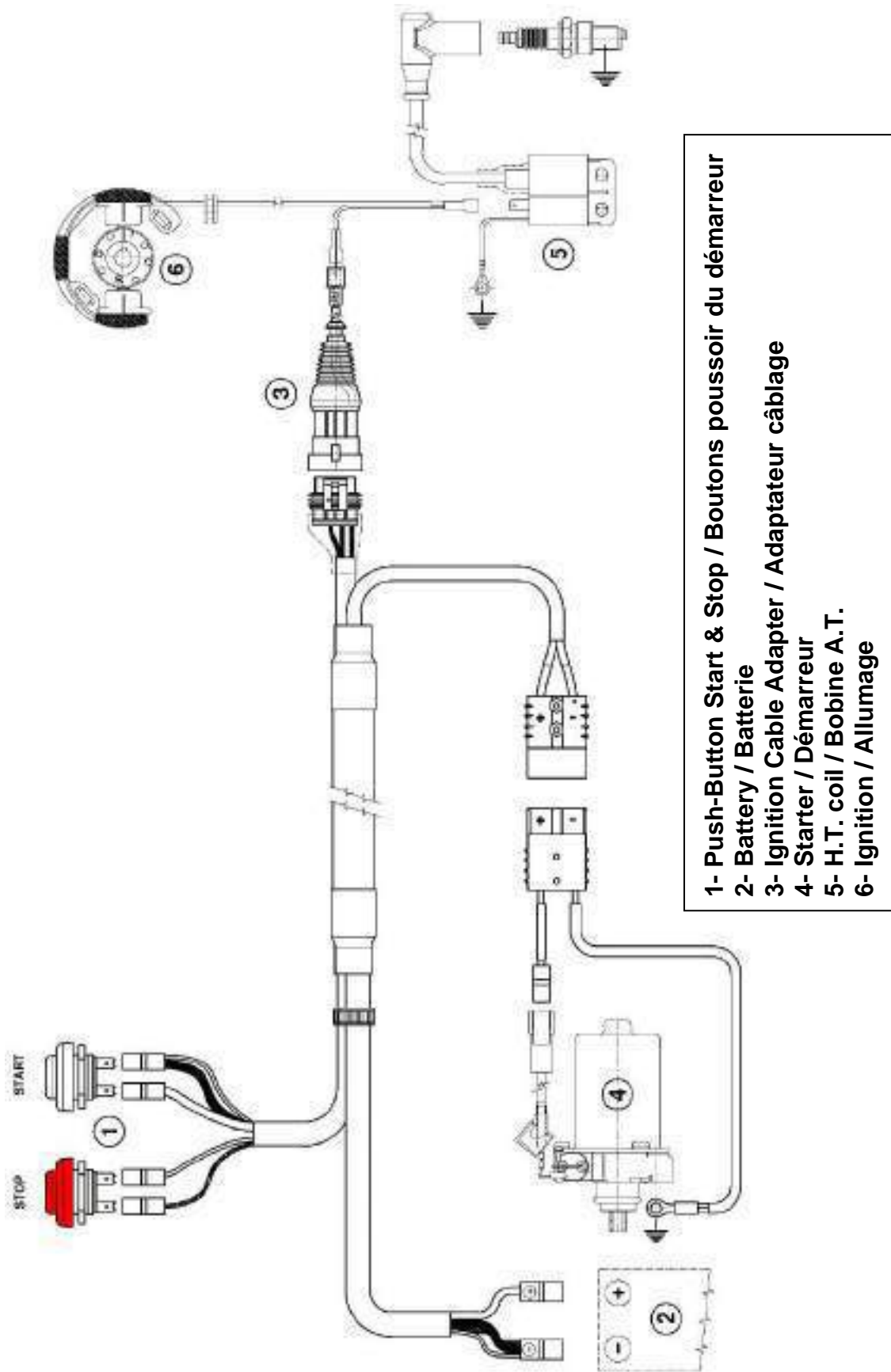

PHOTO OF ALTERNATIVE COMPLETE WIRING LOOM
PHOTO DU CÂBLAGE ÉLECTRIQUE COMPLÈTE ALTERNATIF



WATER PUMP ALTERNATIVES – ALTERNATIVES DU POMPE A' EAU



PLASTIC

RACE BOTTOM *FOND GORGE* $\varnothing 19 \pm 1$

ALTERNATIVE



ALUMINUM

RACE BOTTOM - *FOND GORGE* $\varnothing 20 \pm 1$



PULLEY ALTERNATIVE – ALTERNATIVE DU POULIE

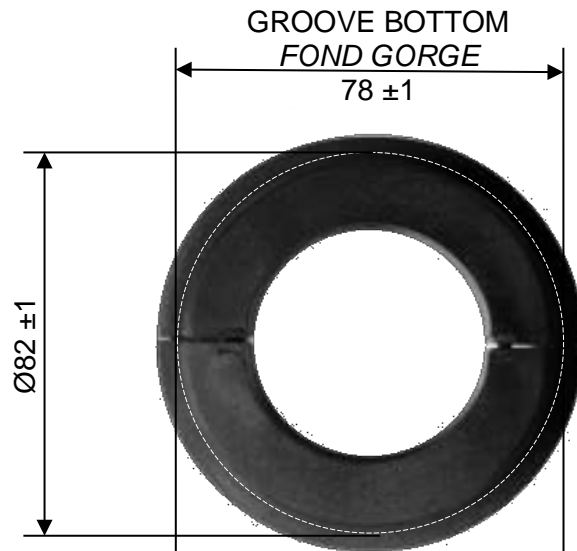

PLASTIC



ALTERNATIVE



ALUMINUM

RADIATOR AND ITS SUPPORTS
RADIATEUR ET SES SUI TIEN

PAINTED AND NOT PAINTED
PEINT ET PAS PEINT

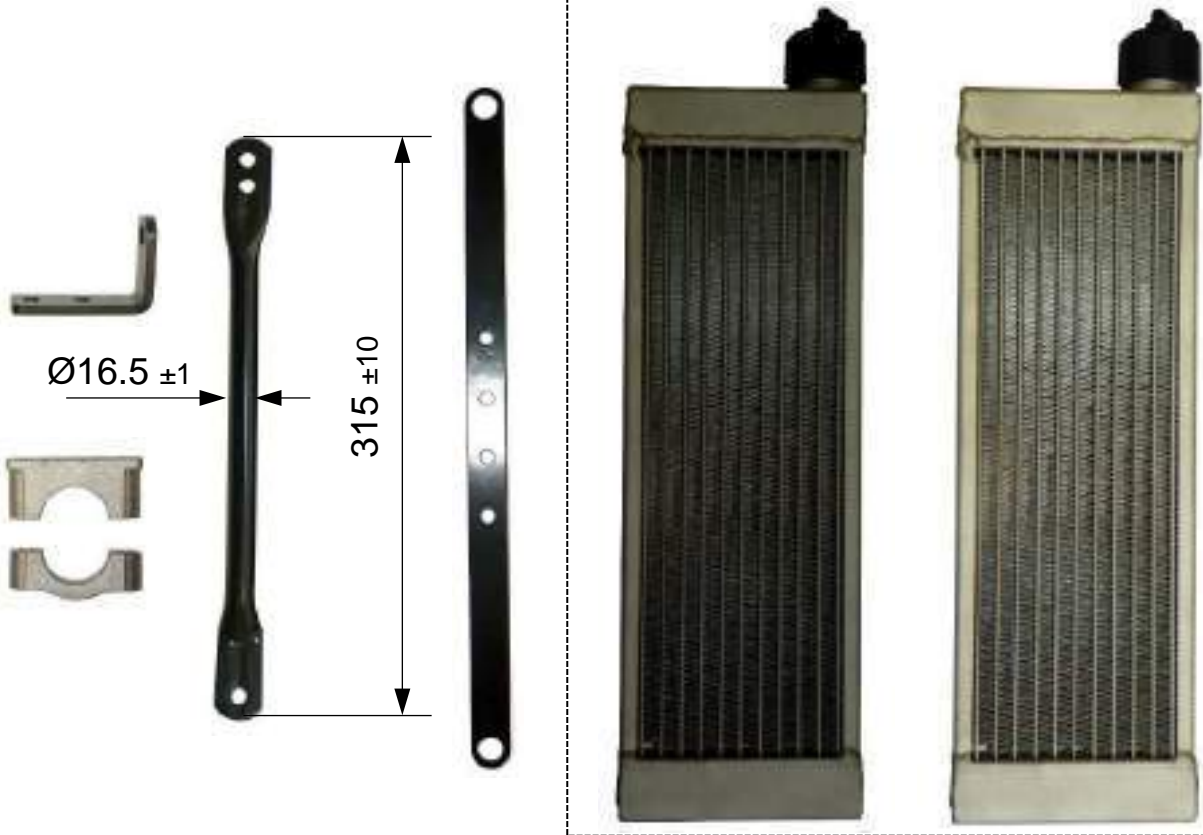

ALTERNATIVE RADIATOR
RADIATEUR ALTERNATIF



ALTERNATIVE RADIATOR SUPPORT
ALTERNATIVE SUI TIEN DU RADIATEUR

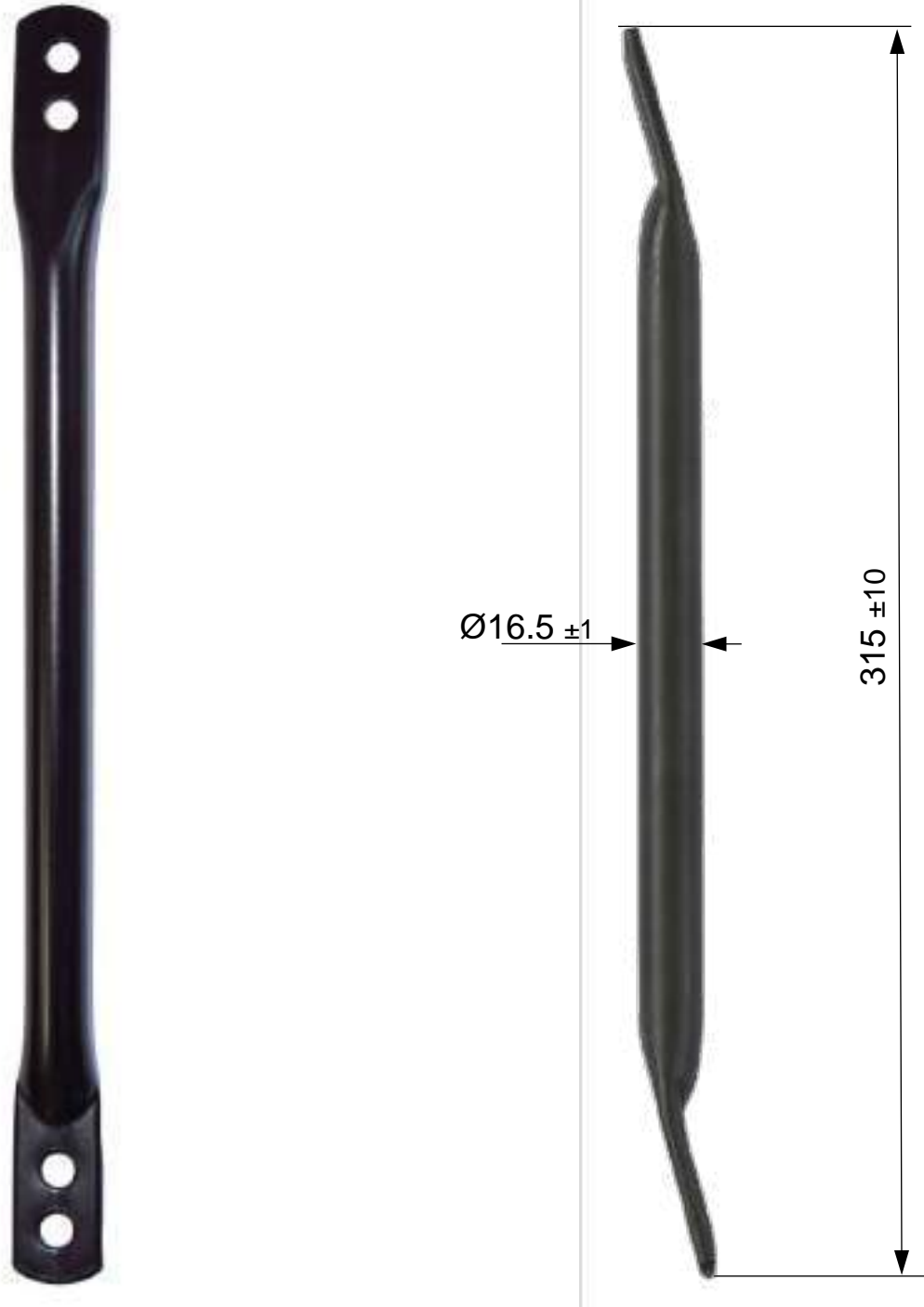

CYLINDER IDENTIFICATION MARKING
MARQUAGE D'IDENTIFICATION DU CYLINDRE



* Compulsory from engine n. 011150
Obligatoire à partir du moteur no. 011150

CYLINDER BASE ALTERNATIVE MARKING
MARQUAGE ALTERNATIF DU LA BASE CYLINDRE

ALTERNATIVE

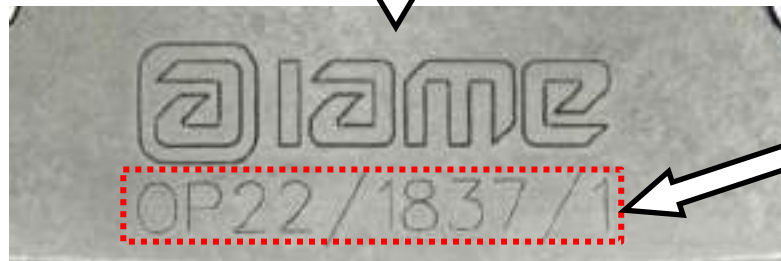
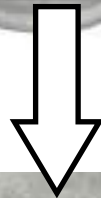

VARIABLE



CYLINDER HEAD MARKING
 MARQUAGE D'IDENTIFICATION DU CULASSE



OR



SEMICARTER TRANSMISSION SIDE
 SEMICARTER CÔTÉ PIGNON

SEMICARTER IGNITION SIDE
 SEMICARTER CÔTÉ ALLUMAGE



OR



OR



PHOTO IDENTIFICATION OF CONROD – TYPES ALTERNATIVE
PHOTO D' IDENTIFICATION DE LA BIELLE – TYPES ALTERNATIFS

TYPE 1



TYPE 2



PISTON IT1 TYPES IDENTIFICATION
IDENTIFICATION DES TYPES DU PISTON IT1
*(dimensions and weight are the same for both types /
 les dimensions et le poids sont les mêmes pour les deux types)*

CURRENT / COURANT

ALTERNATIVE / ALTERNATIF

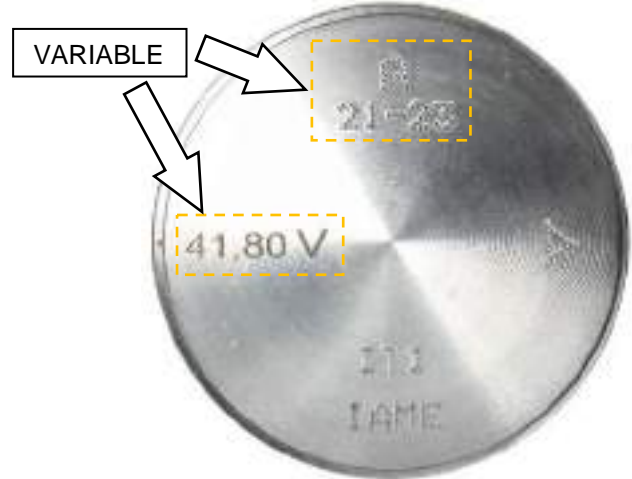
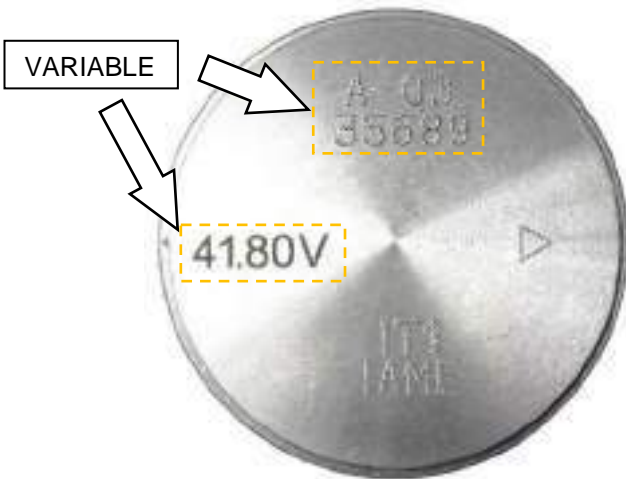

SPROCKET IDENTIFICATION MARKING
 MARQUAGE D'IDENTIFICATION DU PIGNON

CLUTCH DRUM IDENTIFICATION MARKING
 MARQUAGE D'IDENTIFICATION DE LA
 CALOTTE



CLUTCH BODY IDENTIFICATION MARKING
 MARQUAGE D'IDENTIFICATION DU CORPS
 DE L'EMBRAYAGE

STARTER RING IDENTIFICATION MARKING
 MARQUAGE D'IDENTIFICATION DE LA
 COURONNE DE DEMARRAGE



CRANKSHAFT AND HIS COMPONENTS IDENTIFICATION MARKING
MARQUAGE D'IDENTIFICATION DU VILEBREQUIN ET SES COMPOSANTS



BENDIX COVER IDENTIFICATION MARKING
MARQUAGE D'IDENTIFICATION DU COUVERCLE
DU CONTRE-ARBRE DE DEMARRAGE



STARTER IDENTIFICATION MARKING
MARQUAGE D'IDENTIFICATION DU DEMARREUR

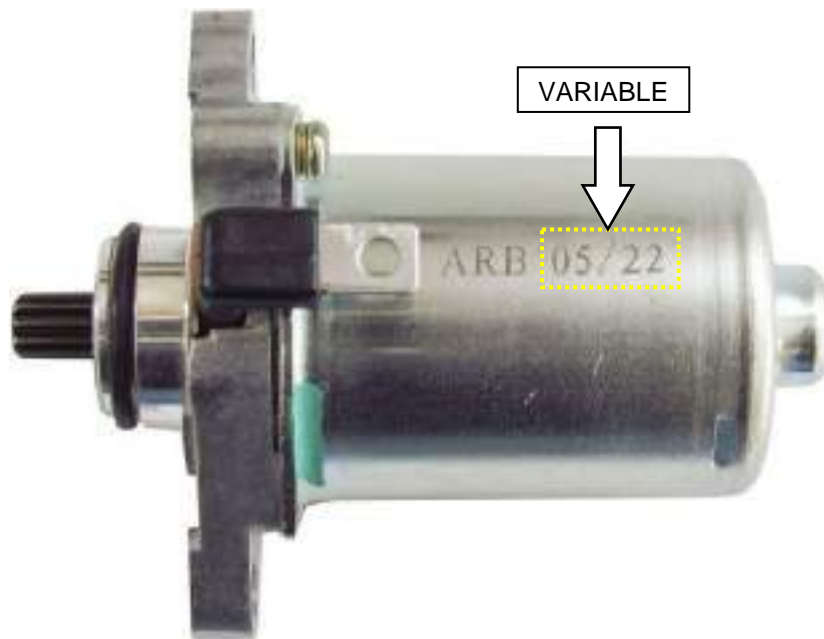
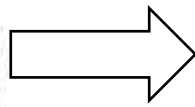
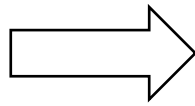
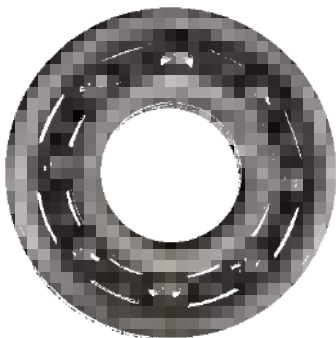

PHOTO IDENTIFICATION: SMALL & BIG END CONROD BEARING AND MAIN BEARING
PHOTO D'IDENTIFICATION DU ROULEMENT PIED/TÊTE DE BIELLE ET PRINCIPAUX



ALTERNATIVE



EXHAUST IDENTIFICATION MARKING without embossed logo
MARQUAGE D'IDENTIFICATION ECHAPPEMENT sans logo en relief

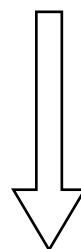

IGNITION COVER
COUVERCLE DU ALLUMAGE



OR



CLUTCH COVER
COUVERCLE D'EMBAYAGE



OR



INLET FILTER
SILENCIEUX D'ASPIRATION



OR



THE OTHERS COMPONENTS OF ENGINE THAT ARE MARKED (LASER OR PUNCHING) UNTIL TODAY WITH LOGO OR WRITTEN "IAME"

LES AUTRES COMPOSANTS DU MOTEUR AVEC MARQUAGE (LASER OU POINÇONNEUSE) AUJOURD'HUI AVEC LE LOGO OU ÉCRIT «IAME»

I A M E

or

IAME

NOW COULD BE MARKED WITH NEW LOGO "IAME"
MAINTENANT POURRAIT EST MARQUAGE AVEC UN NOUVEAU LOGO
"IAME"

i a m e

or

@ i a m e

or

@

NO GO GAUGES
OUTILS N'ENTRE PAS DANS

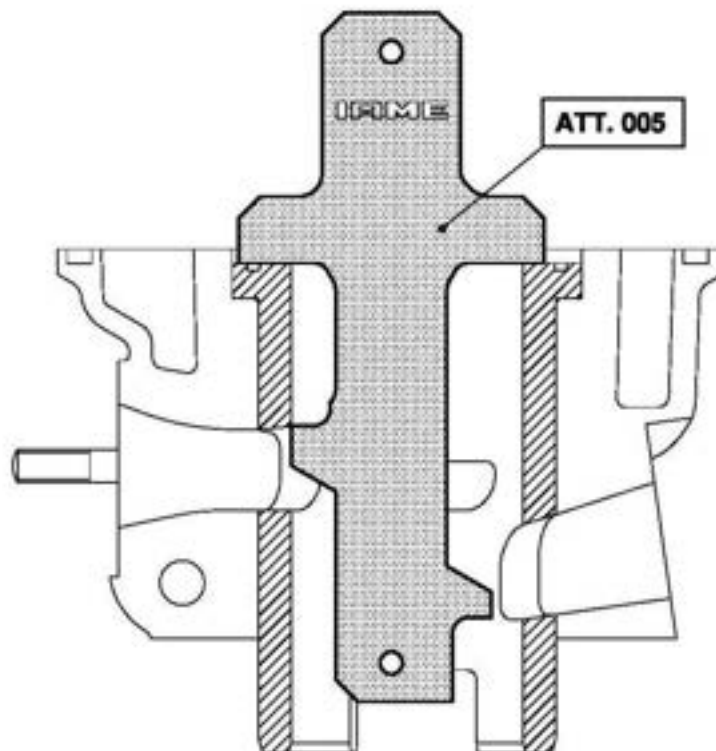
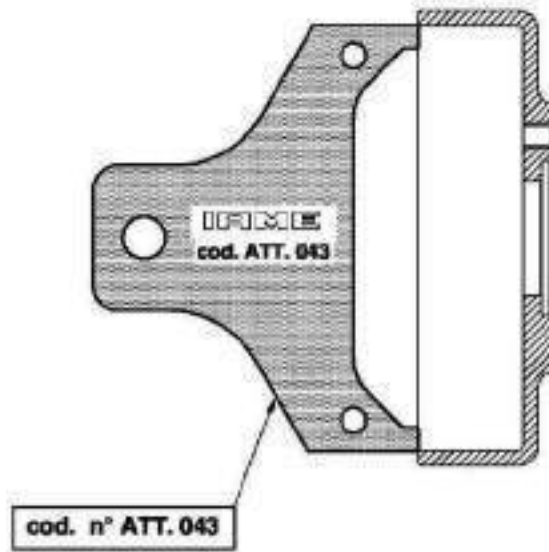

NO GO GAUGES
OUTILS N'ENTRE PAS DANS

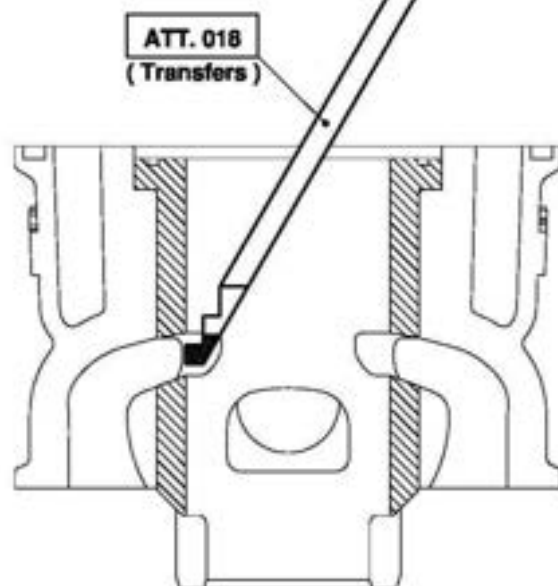
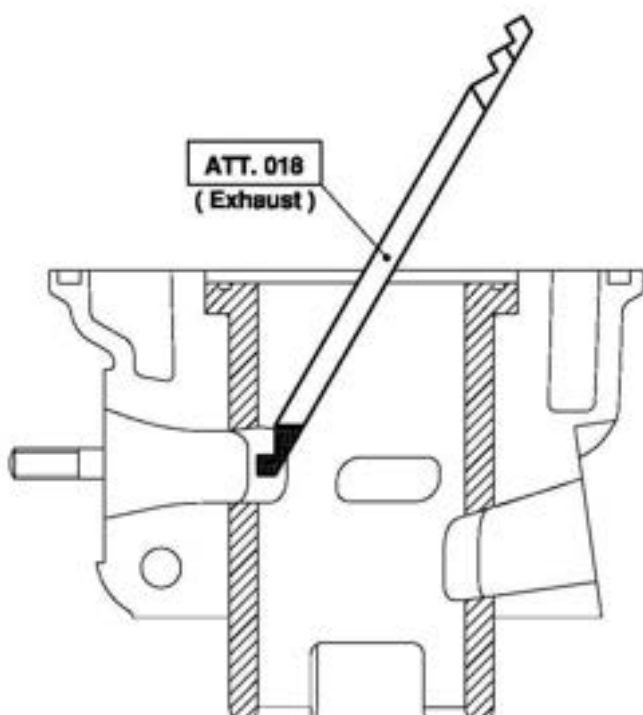
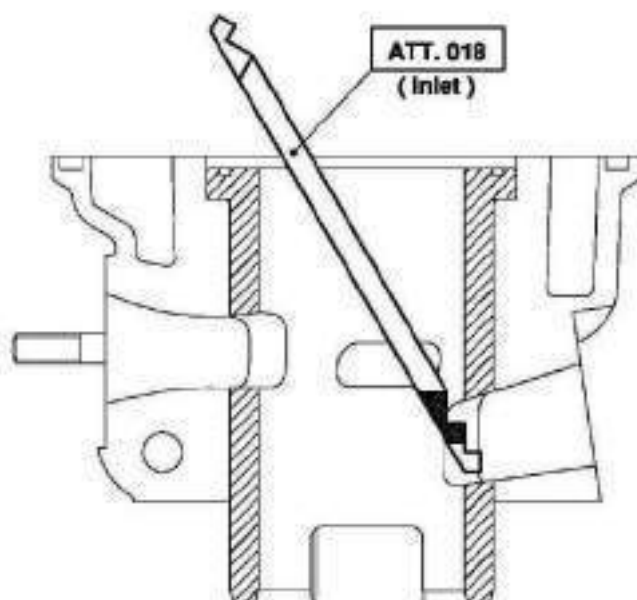

CONTROL GAUGES
OUTILS DE CONTROLL

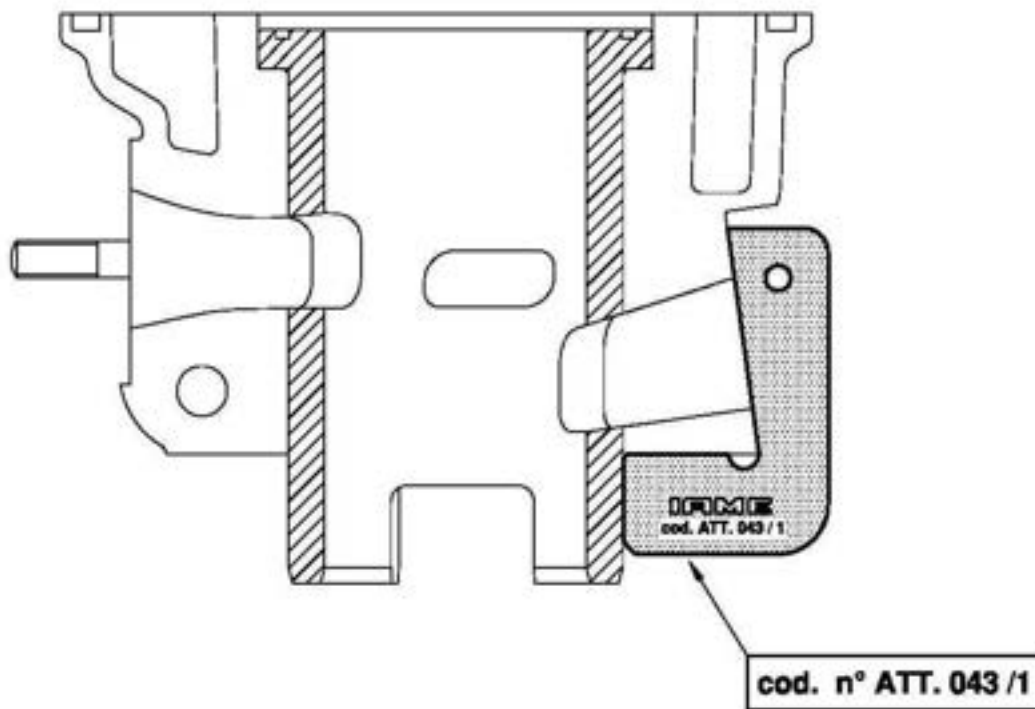
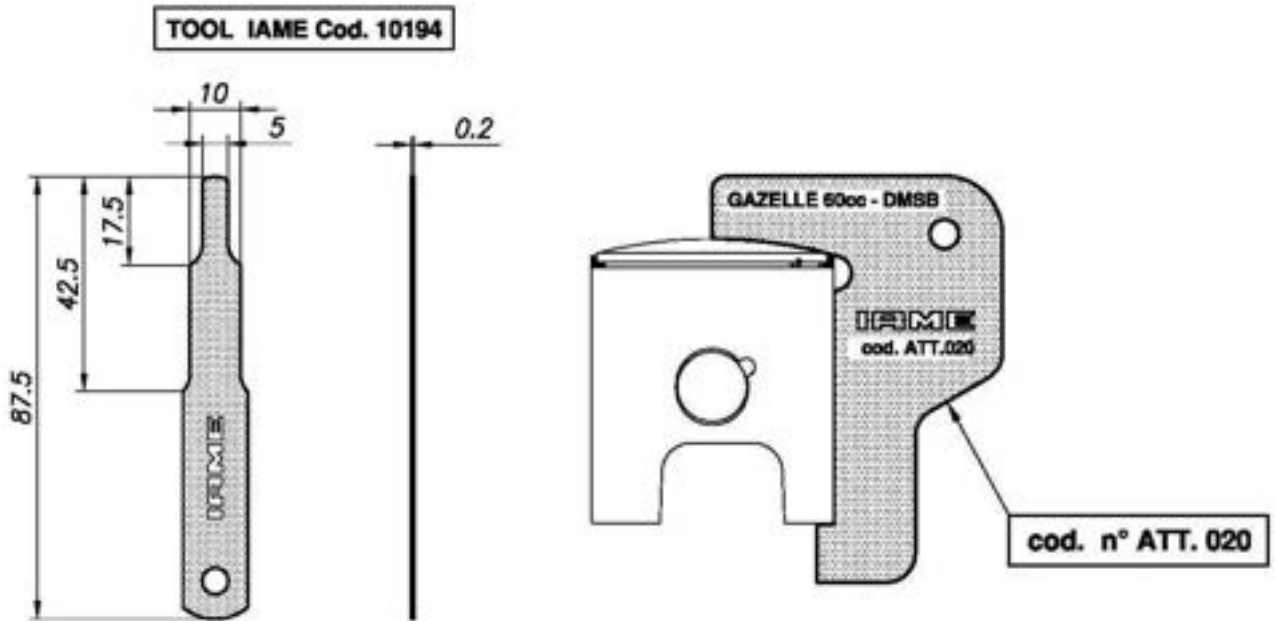

**CONTROL GAUGES
OUTILS DE CONTROLL**

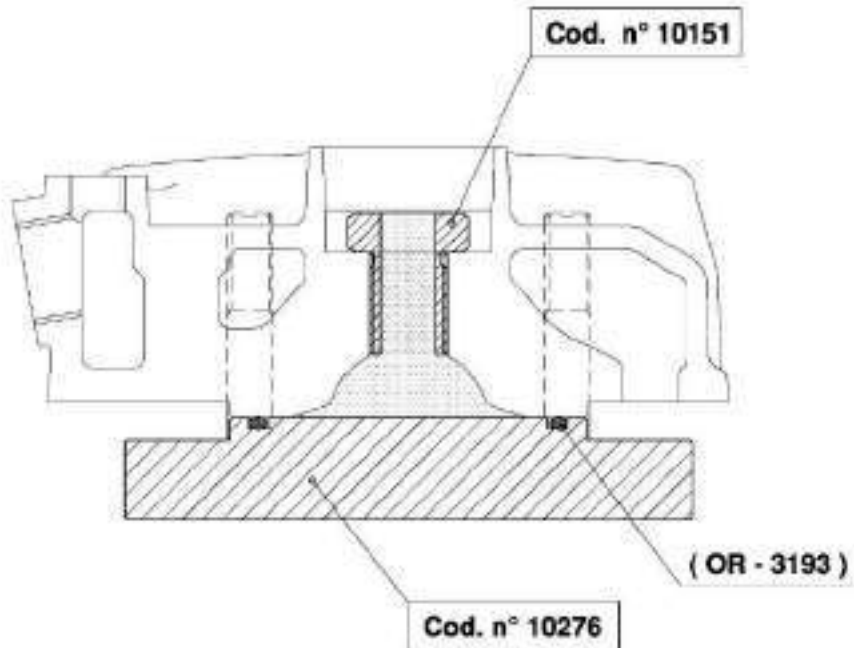
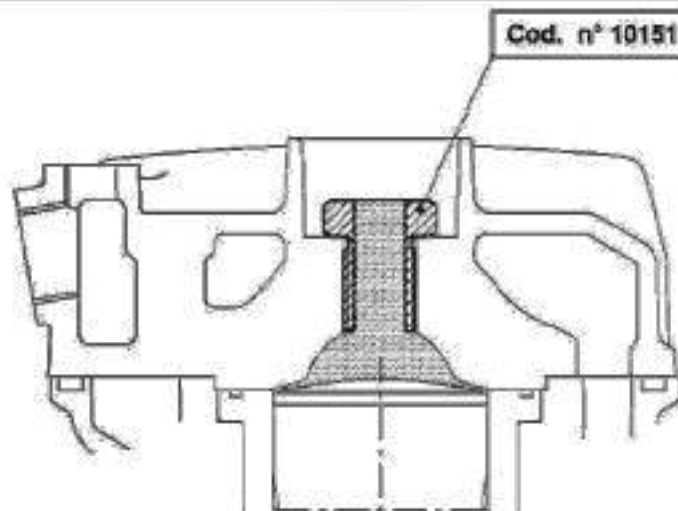
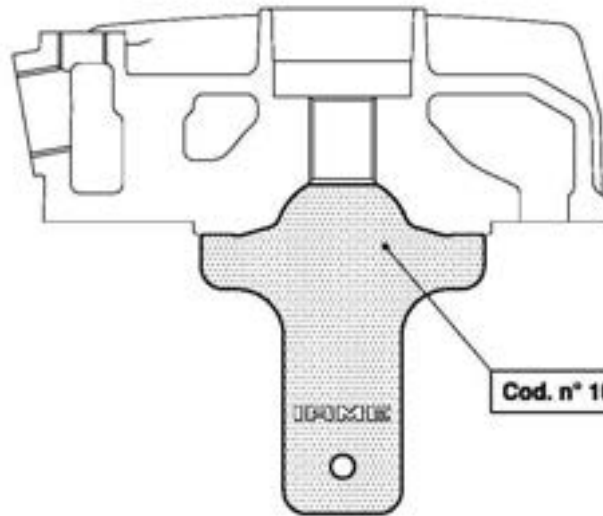

**CONTROL GAUGES
OUTILS DE CONTROLL**

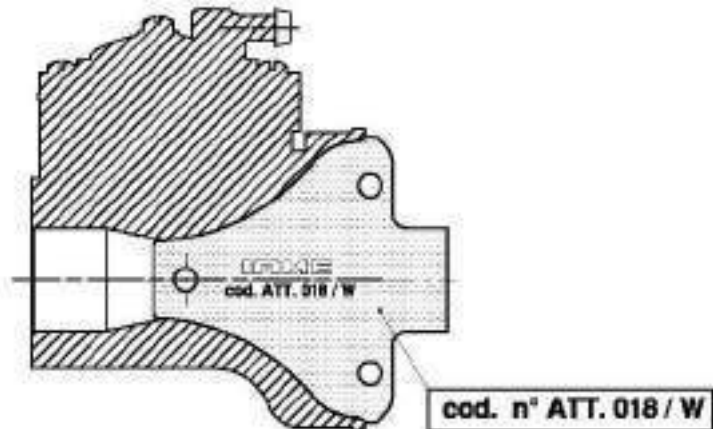

Check that the tool must be the same shape of the inlet carburettor.
Vérifier que l'outil doit avoir la même forme que l'admission du carburateur.

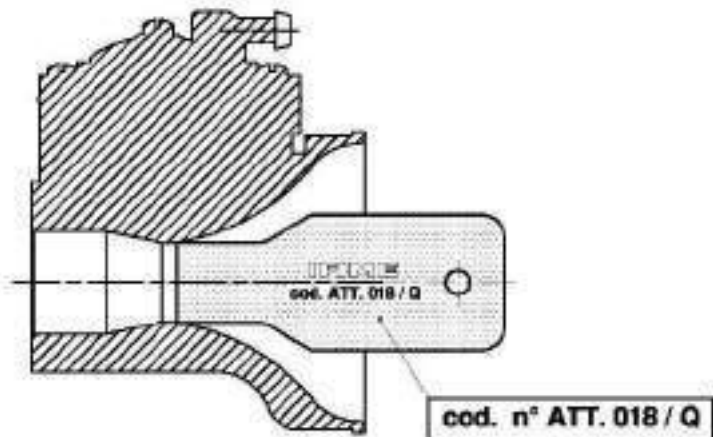

Check that the tool does not enter into the venturi duct inlet of carburettor.
Vérifier que l'outil n'entre pas dans l'entrée du conduit Venturi du carburateur.

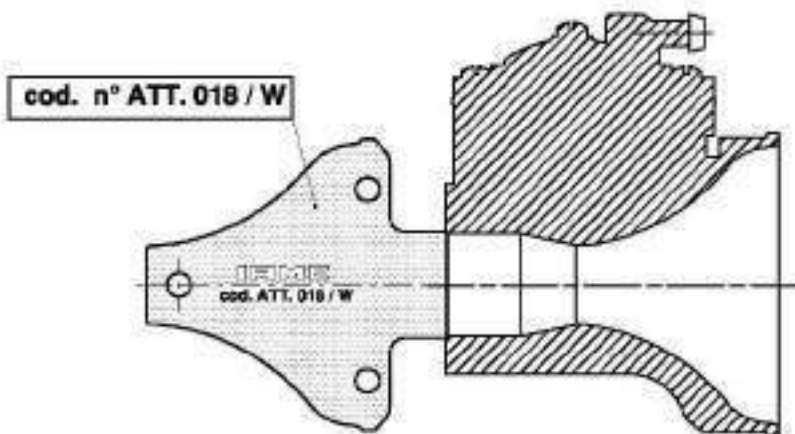

Check that the tool does not enter into the venturi duct outlet of carburettor.
Vérifier que l'outil n'entre pas dans la sortie du conduit Venturi du carburateur.

**CONTROL GAUGES
OUTILS DE CONTROLL**

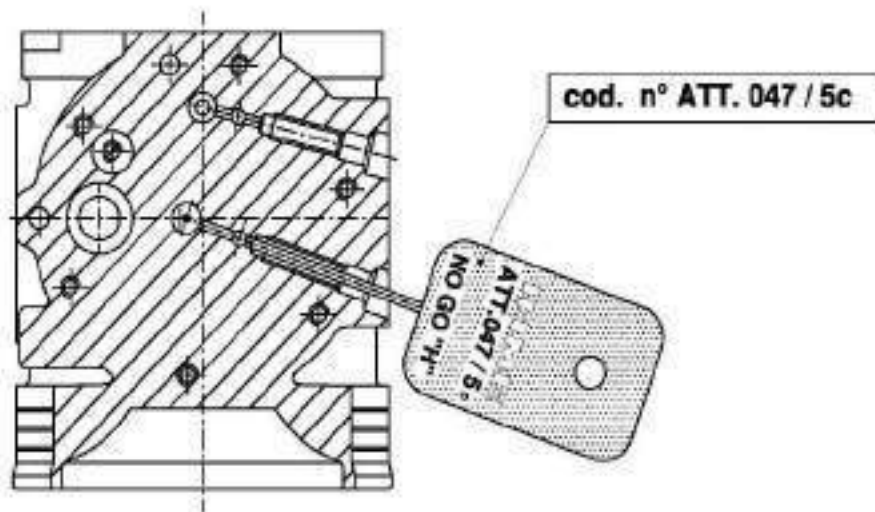
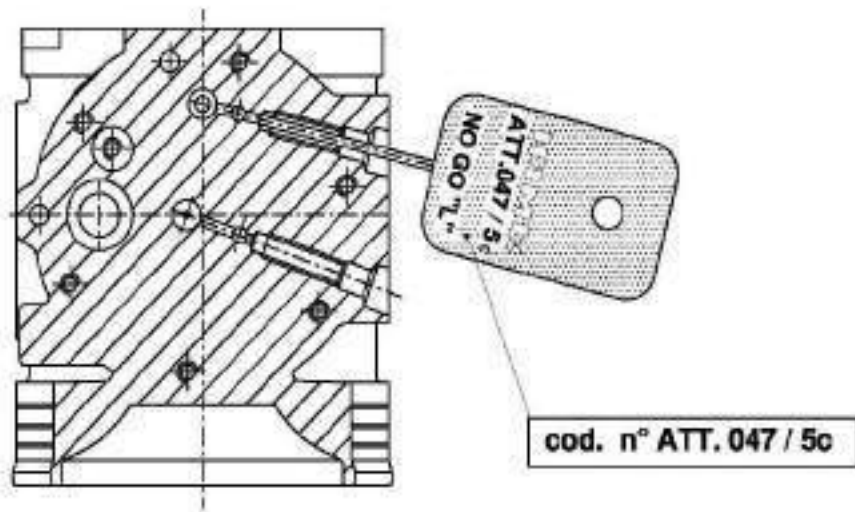

Check that the spikes does not enter into the holes.
Vérifiez que les pointes n'entrent pas dans les trous.

**CONTROL GAUGES
OUTILS DE CONTROL**

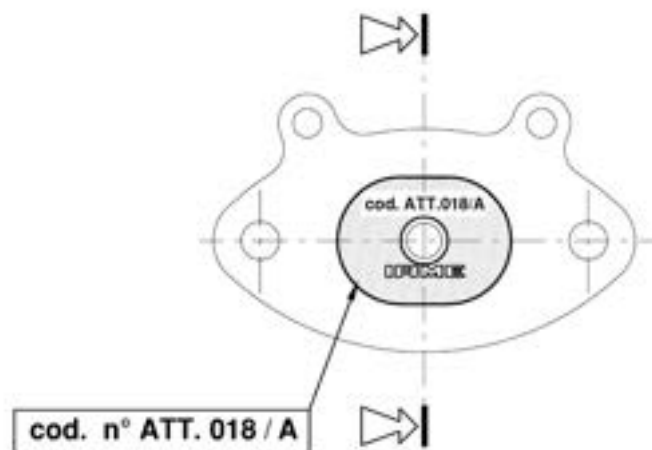
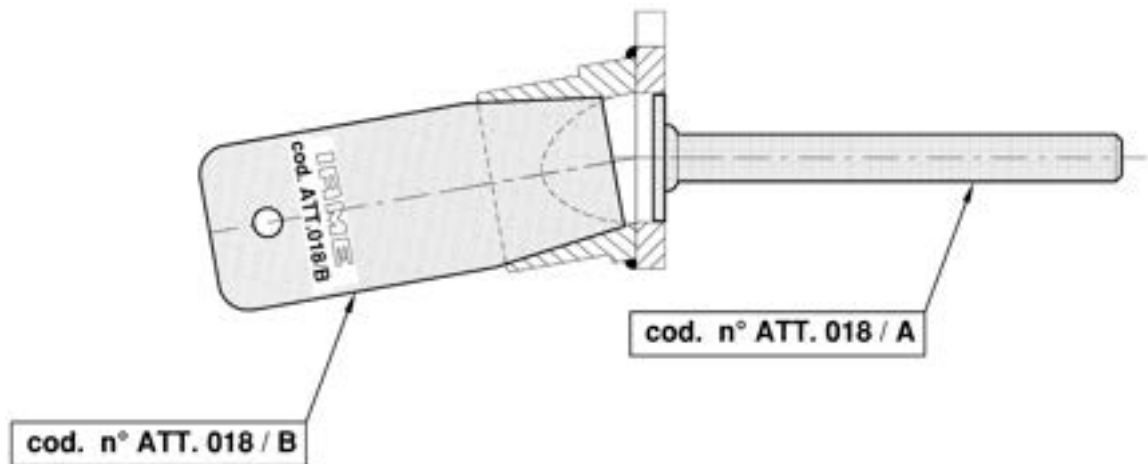

Check that the tool must be the same shape of the exhaust manifold.
Vérifiez que l'outil doit être de la même forme du collecteur d'échappement

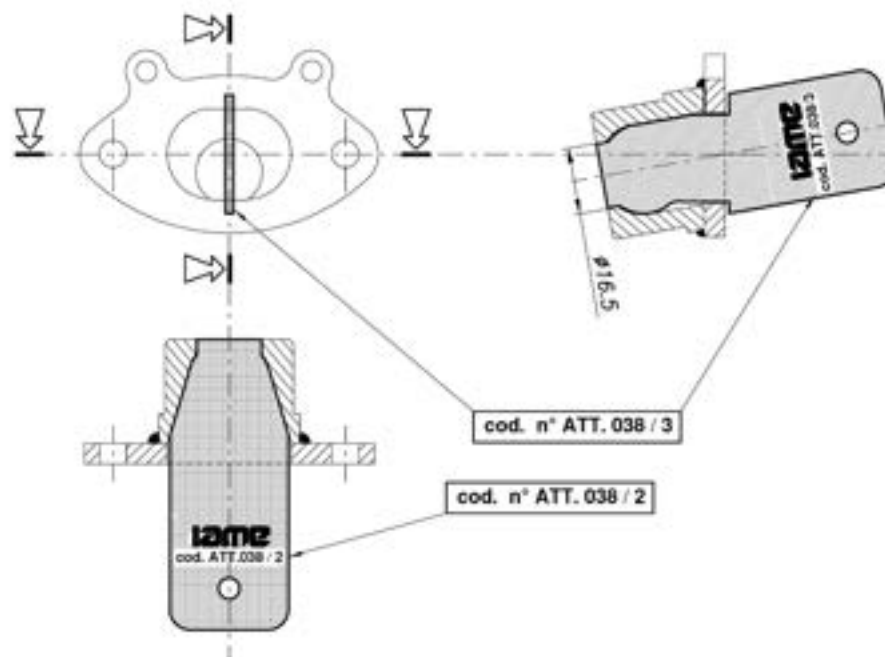

Check that the tool must be the same shape of the inlet carburettor.
Vérifier que l'outil doit avoir la même forme que l'admission du carburateur.

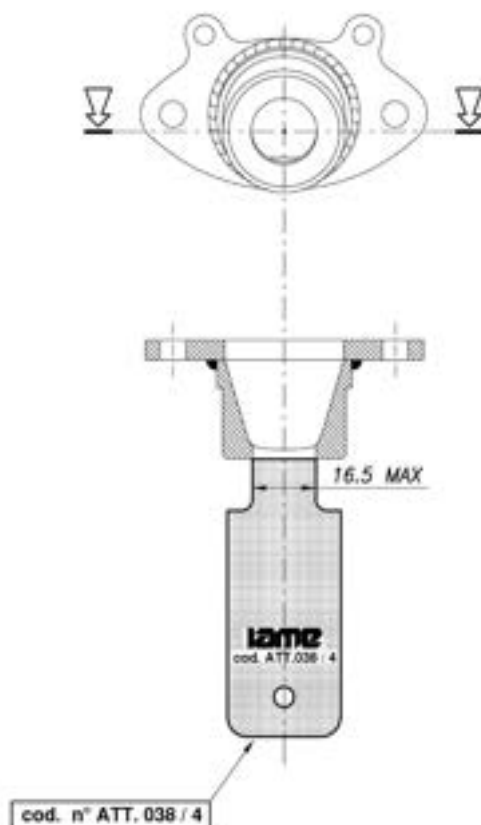

Check that the tool does not enter into the exhaust restrictor.
Vérifier que l'outil n'entre pas dans le restricteur d'échappement

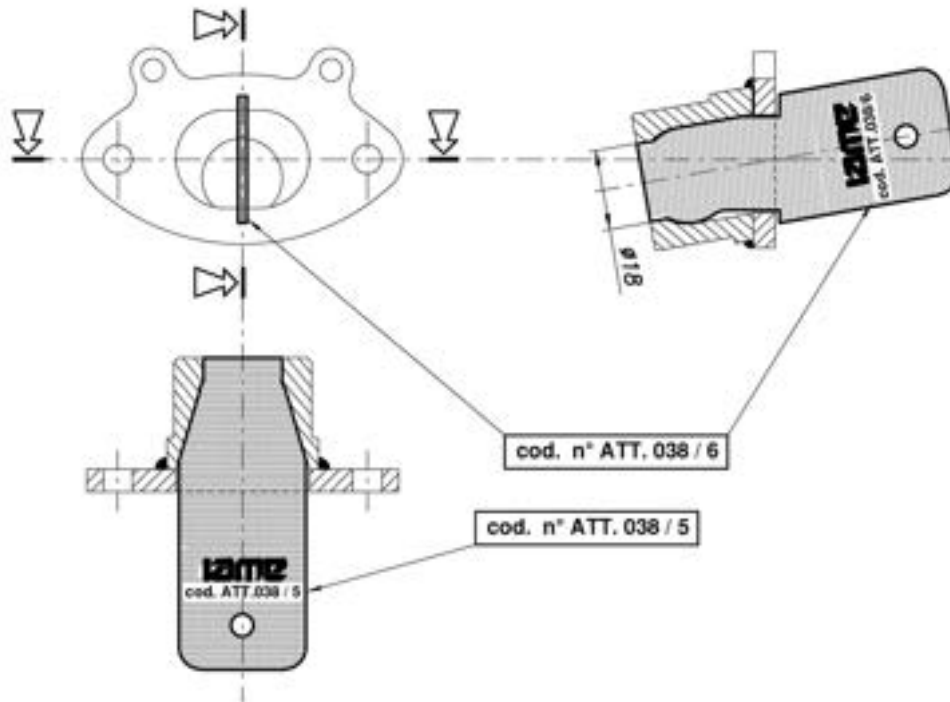

Check that the tool must be the same shape of the inlet carburettor.
Vérifier que l'outil doit avoir la même forme que l'admission du carburateur.

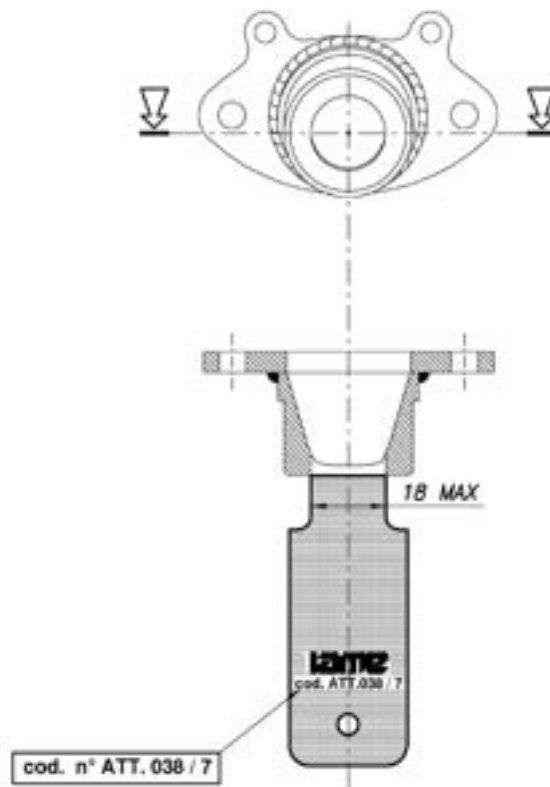

Check that the tool does not enter into the exhaust restrictor.
Vérifier que l'outil n'entre pas dans le restricteur d'échappement



CARBURETTOR / CARBURATEUR
Tillotson HW-31A



PHOTO OF ADJUSTING SIDE
 PHOTO CÔTÉ RÉGLAGE



PHOTO OF INLET SIDE
 PHOTO CÔTÉ ASPIRATION

Manufacturer - <i>Constructeur</i>	TILLOTSON LTD.
Make - <i>Marque</i>	TILLOTSON
Model - <i>Modèle</i>	HW-31A

SECTION VIEW – VUE DE SECTION AVEC DIMENSIONS

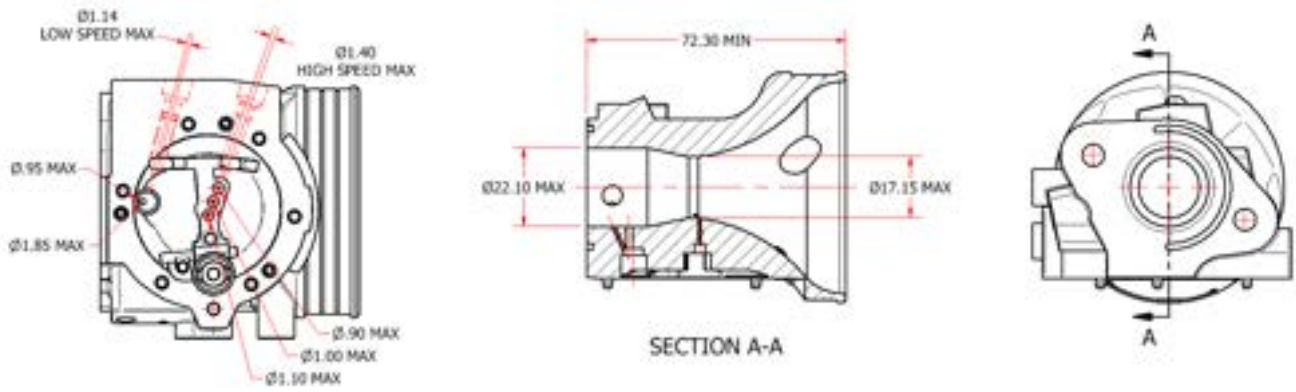

“IAME” MARKING – MARQUAGE “IAME”

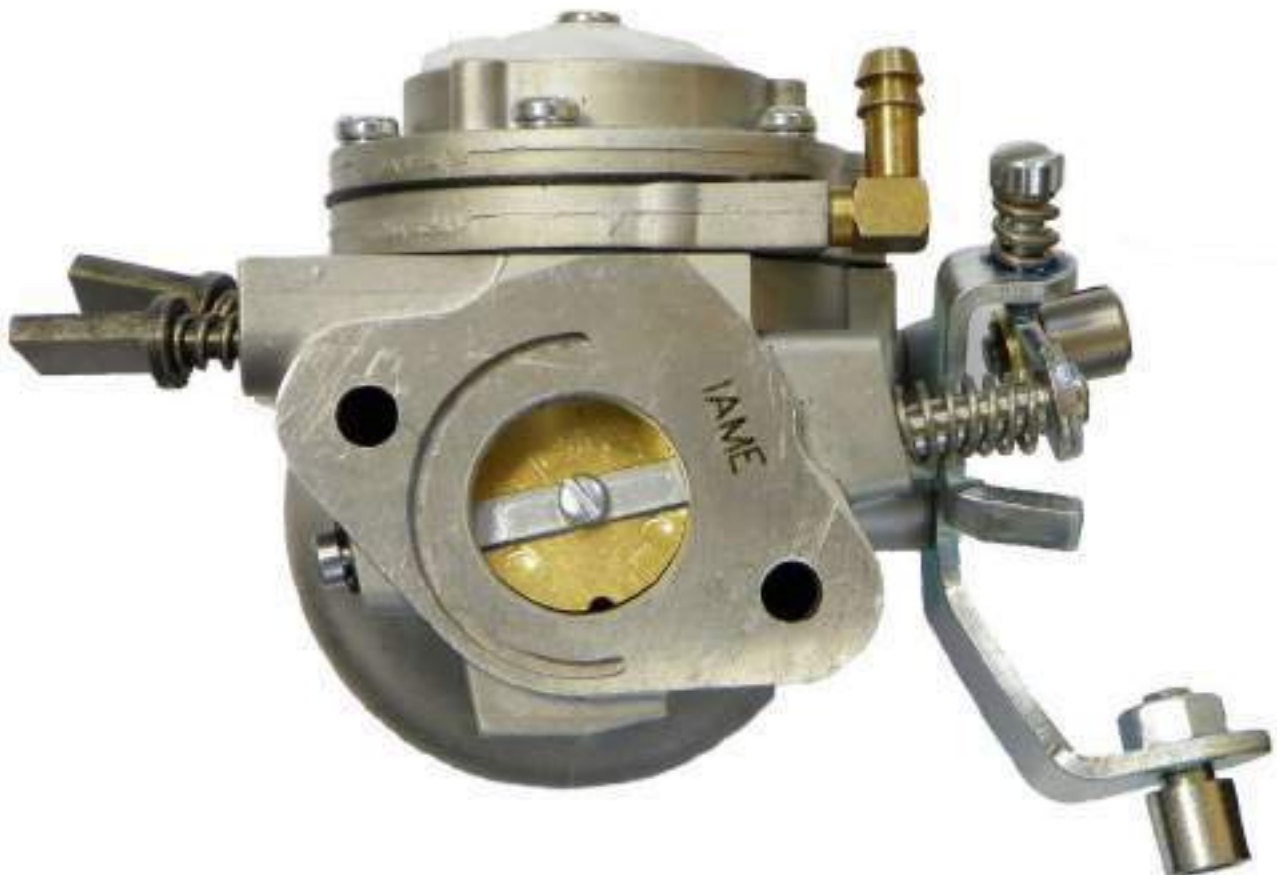

CARBURETTOR - DESCRIPTION AND SKETCH OF PARTS
 CARBURATEUR - DESCRIPTION ET DESSIN DES PIÈCES

HW-31A



ITEM	PART NO.	DESCRIPTION	QTY
9	+ * 30-0311	DIAPHRAGM GASKET	1
10	+ * 237-600	DIAPHRAGM	1
11	91-1036	DIAPHRAGM COVER	1
12	+ * 36-8300	FUEL PUMP GASKET	1
14	+ * 237-162	FUEL PUMP DRIVE SHAFT	1
15	341-80	FUEL PUMP BODY	1
16	15C-51	FUEL PUMP BODY SCREW	6
17	86-178	FUEL STRAINER COVER	1
18	+ * 36-8205	FUEL STRAINER COVER GASKET	1
19	81-8251	FUEL STRAINER COVER	1
20	15-8313	FUEL STRAINER COVER RETAINING SCREW	1
21A	45-1034	IDLE MIXTURE SCREW	1
21B	21-0449	IDLE MIXTURE SCREW SPRING	1
21C	76A-256	IDLE MIXTURE SCREW WASHER	1
21D	44-361	IDLE MIXTURE SCREW PACKING	1
22	+ * 350A-07	INLET CONTROL LEVER	1
23	15-8329	FULL THROTTLE LEVER SCREW	1
23A	38-19	FULL THROTTLE LEVER PIN	1
27	+ * 233-726P	INLET NEEDLE & SEAT SET	1
28	15-0189	INLET SEAT GASKET	1
29	24-0373	INLET THROTTLE SPRING	1
30A	45-1034	HIGH SPEED FIXTURE SCREW	1
30B	76A-349	HIGH SPEED FIXTURE SCREW SPRING	1
30C	76A-256	HIGH SPEED FIXTURE SCREW WASHER	1
30D	44-361	HIGH SPEED FIXTURE SCREW PACKING	1
33	25-224	THROTTLE SHAFT CLIP	1
35	15-C16	THROTTLE SHAFT CLIP RETAINING SCREW	1
36	24-0381	THROTTLE RETURN SPRING	1
37	11-466	THROTTLE SHUTTER	1
38	15-C20	THROTTLE SHUTTER SCREW	1
42	15-8215	THROTTLE SHAFT	1
43	12-1218	THROTTLE LEVER ASSEMBLY	1
44	15-C20	THROTTLE LEVER RETAINING SCREW	1
52	119-62	WELCH LEG	1
54	85-185	MAIN PILE	2
55	136-550	CABLE BRACKET	1
56	15-C20	CABLE BRACKET RETAINING SCREW	2
57	15-C20	LIMITER SCREW	2
58	24-0131	LIMITER SPRING	2
60	81-377	CARBURETTOR MOUNTING KIT	2
86-7409		REPAIR KIT	
DU-1HW		DIAPHRAGM & GASKET (STANDARD)	
233-726P		INLET NEEDLE & SEAT SET	
* INDICATES CONTENTS OF REPAIR KIT			
+ INDICATES CONTENTS OF DIAPHRAGM & GASKET SET			



Clash Industrial Estate - Tralee - Ireland
 www.tillotson-racing.com



PARTS OF CARBURETTOR – PIÈCES DU CARBURATEUR

REF.9 - P. N°16-B217
DIAPHRAGM GASKET
JOINT DE DIAPHRAGME

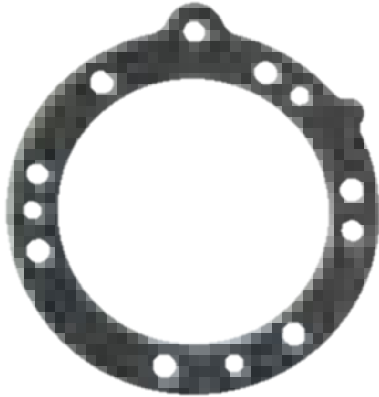

Thickness / *Epaisseur* = 0.5 ±0.1 mm

REF.13 - P. N° 16-B392
PUMP DIAPHRAGM GASKET
JOINT DE POMPE A ESSENCE

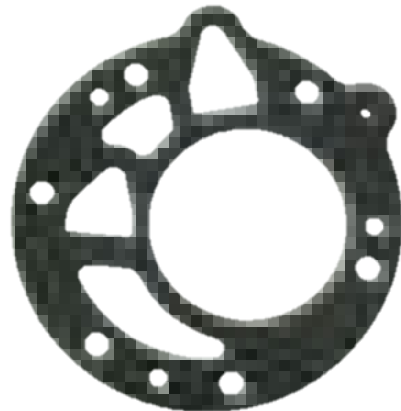

Thickness / *Epaisseur* = 0.8 ±0.1 mm

REF.10 - P. N°237-600
DIAPHRAGM
DIAPHRAGME ASSEMBLE



Thickness / *Epaisseur* = 0.13 ±0.07 mm

REF.14 - P. N°237-162
PUMP DIAPHRAGM
MEMBRANE DE POMPE A ESSENCE



Thickness / *Epaisseur* = 0.10 ±0.063 mm

REF.11 - P. N° 91-1031
DIAPHRAGM COVER
COUVERCLE DE DIAPHRAGME







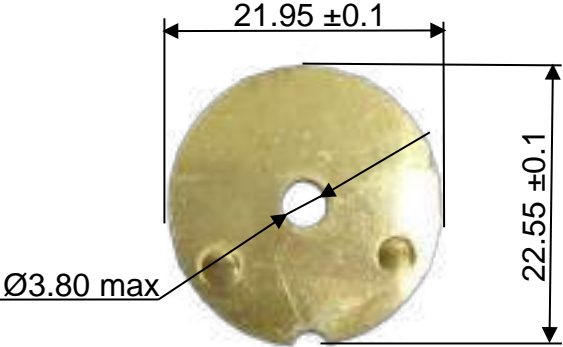

Thickness / *Epaisseur* = 6.75 ±0.15 mm

REF.15 - P. N° 141-89
PUMP COVER
CORPS DE POMPE A ESSENCE



Thickness / *Epaisseur* = 12.5 ±0.15 mm

<p>REF.37 - P. N° 14-A96 THROTTLE SHUTTER PAPILLON</p>  <p>Thickness / <i>Epaisseur</i> = 0.81 ±0.1 mm</p>	<p>REF.27 - P. N° 233-720P SEAT + NEEDLE SIEGE + POINTEAU</p> 
<p>REF.21A - P. N° 43-1034 NEEDLE LOW SPEED VIS DE RAGLAGE BAS-REGIME</p> 	<p>REF.30A - P. N° 43-1034 NEEDLE HIGH SPEED VIS DE RAGLAGE HAUT-REGIME</p> 
<p>ALTERNATIVE NEEDLE FUEL POINTEAU ALTERNATIVE</p>	<p>HOLE FOR CARBURETTOR SEALING TROU POUR LE PLOMBAGE</p>
<p>REF.27 - P. N° 233-720P</p> 	<p>The carburettor can have this hole for sealing. <i>Le carburateur peut avoir ce trou pour le plombage</i></p>  <p>Ø3 HOLE / TROU</p>