

<b>FABRICANTE</b>	<b>MANUFACTURER</b>	TILLOTSON LTD
<b>MARCA</b>	<b>MAKE</b>	TILLOTSON
<b>MODELO</b>	<b>MODEL</b>	HW-27 <sup>a</sup>
<b>CATEGORIA</b>	<b>CATEGORY</b>	JUNIOR-SENIOR
<b>VALIDEZ HOMOLOGACION</b>	<b>VALIDITY OF HOMOLOG</b>	2018
<b>Nº DE PAGINAS</b>	<b>Nº OF PAGES</b>	5



PHOTO OF ADJUSTING SIDE /  
FOTO DEL LADO DE AJUSTE

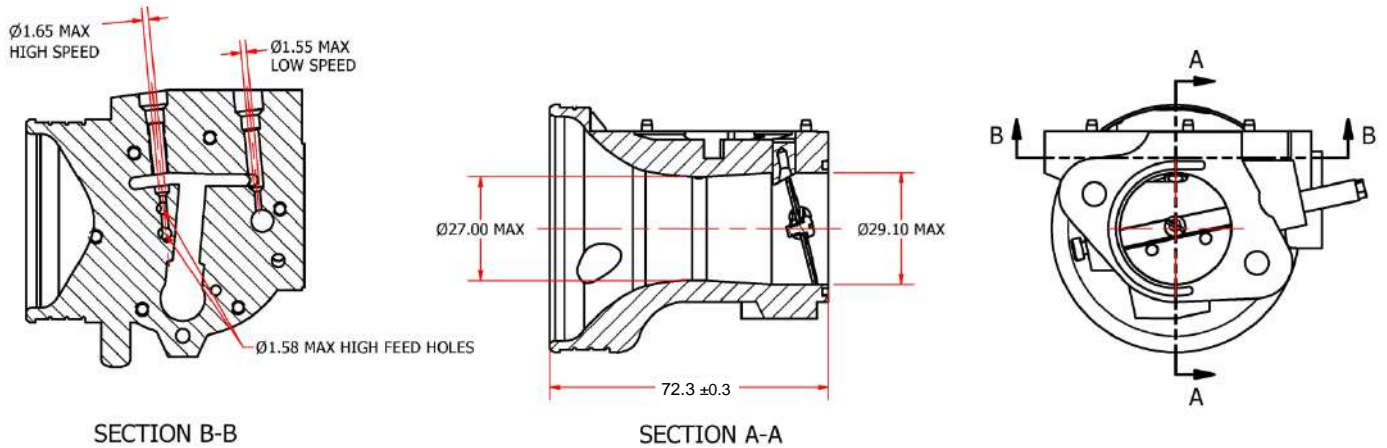

PHOTO OF INLET SIDE /  
FOTO DEL LADO DE ADMISIÓN

\*All measures are expressed in mm, unless otherwise indicated.

\*Todas las cotas están expresadas en mm, salvo que se indique lo contrario.

SECTION VIEW / VISTA SECCIONADA



MARKING / MARCAJE

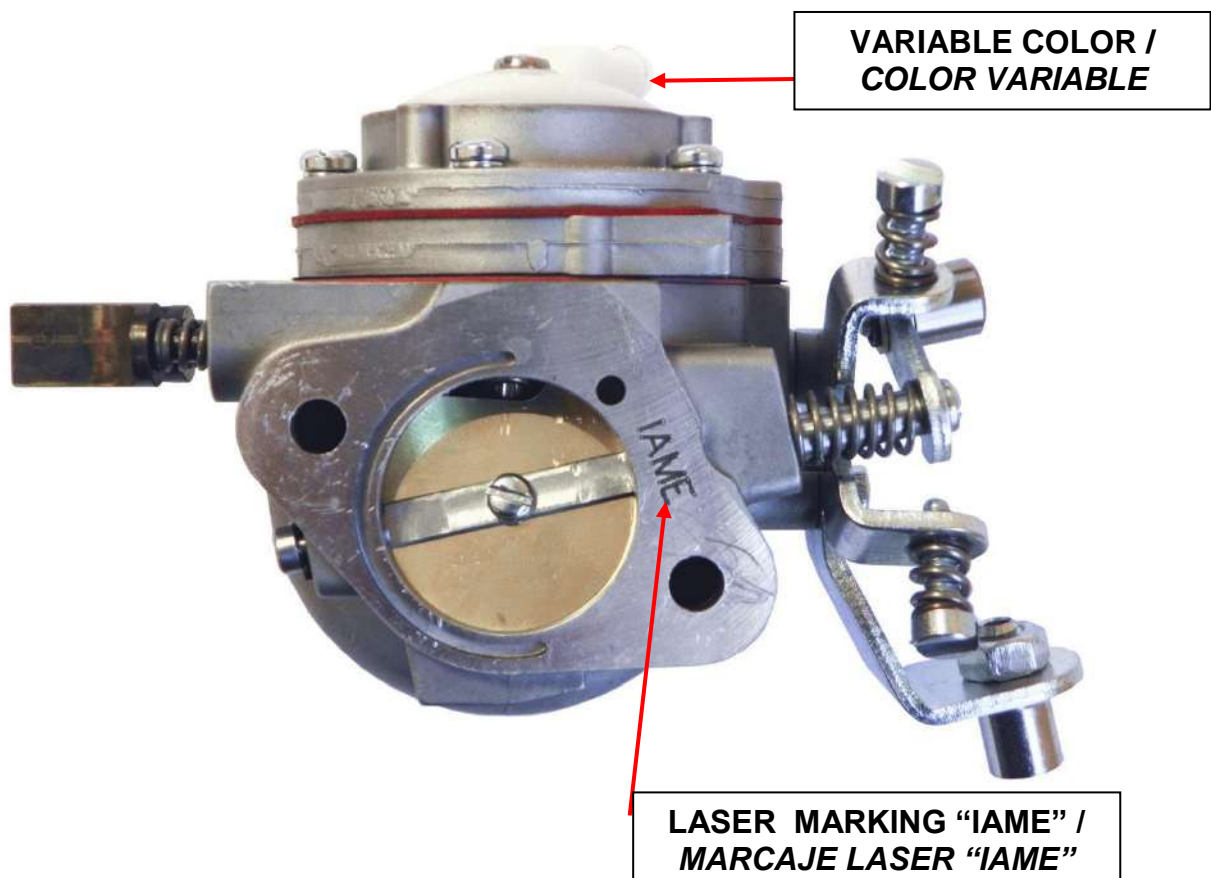

CARBURETOR DESCRIPTION AND SKETCH OF PARTS /  
DESCRIPCIÓN DEL CARBURADOR Y ESQUEMA DE PIEZAS

HW-27A

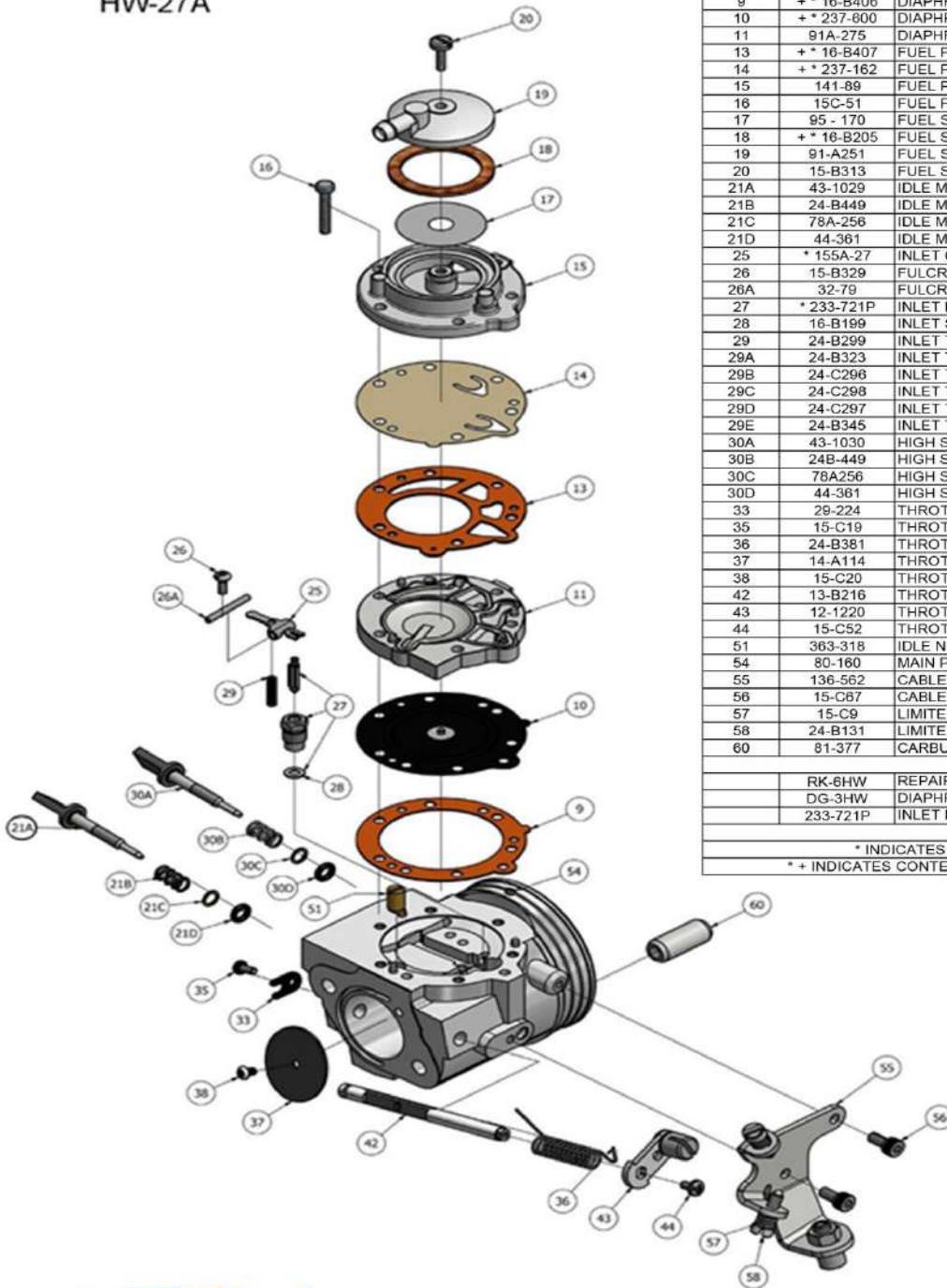

ITEM	PART NO:	DESCRIPTION	QTY
9	+ * 16-B406	DIAPHRAGM GASKET (ORANGE)	1
10	+ * 237-800	DIAPHRAGM	1
11	91A-275	DIAPHRAGM COVER	1
13	+ * 16-B407	FUEL PUMP GASKET (ORANGE)	1
14	+ * 237-162	FUEL PUMP DIAPHRAGM	1
15	141-89	FUEL PUMP BODY	1
16	15C-51	FUEL PUMP BODY SCREW	6
17	95 - 170	FUEL STRAINER SCREEN	1
18	+ * 16-B205	FUEL STRAINER COVER GASKET	1
19	91A-A251	FUEL STRAINER COVER	1
20	15-B313	FUEL STRAINER COVER RETAINING SCREW	1
21A	43-1029	IDLE MIXTURE SCREW	1
21B	24-B449	IDLE MIXTURE SCREW SPRING	1
21C	78A-256	IDLE MIXTURE SCREW WASHER	1
21D	44-361	IDLE MIXTURE SCREW PACKING	1
25	* 155A-27	INLET CONTROL LEVER	1
26	15-B329	FULCRUM LEVER SCREW	1
26A	32-79	FULCRUM LEVER PIN	1
27	* 233-721P	INLET NEEDLE & SEAT SET	1
28	16-B199	INLET SEAT GASKET	1
29	24-B299	INLET TENSION SPRING (STD 37 grams)	1
29A	24-B323	INLET TENSION SPRING (26 grams)	1
29B	24-C296	INLET TENSION SPRING (31 grams)	1
29C	24-C298	INLET TENSION SPRING (42 grams)	1
29D	24-C297	INLET TENSION SPRING (46 grams)	1
29E	24-B345	INLET TENSION SPRING (48 grams)	1
30A	43-1030	HIGH SPEED MIXTURE SCREW	1
30B	24B-449	HIGH SPEED MIXTURE SCREW SPRING	1
30C	78A256	HIGH SPEED MIXTURE SCREW WASHER	1
30D	44-361	HIGH SPEED MIXTURE SCREW PACKING	1
33	29-224	THROTTLE SHAFT CLIP	1
35	15-C19	THROTTLE SHAFT CLIP RETAINING SCREW	1
36	24-B381	THROTTLE RETURN SPRING	1
37	14-A114	THROTTLE SHUTTER	1
38	15-C20	THROTTLE SHUTTER SCREW	1
42	13-B216	THROTTLE SHAFT	1
43	12-1220	THROTTLE LEVER ASSEMBLY	1
44	15-C52	THROTTLE LEVER RETAINING SCREW	1
51	363-318	IDLE NOZZLE	1
54	80-160	MAIN PLUG	2
55	136-562	CABLE BRACKET	1
56	15-C67	CABLE BRACKET RETAINING SCREW	2
57	15-C9	LIMITER SCREW	2
58	24-B131	LIMITER SPRING	2
60	81-377	CARBURETTOR MOUNTING NUT	2
RK-6HW		REPAIR KIT	
DG-3HW		DIAPHRAGM & GASKET (STANDARD)	
233-721P		INLET NEEDLE & SEAT SET	
* INDICATES CONTENTS OF REPAIR KIT			
* + INDICATES CONTENTS OF DIAPHRAGM & GASKET SET			

PARTS OF CARBURETOR /  
PIEZAS DEL CARBURADOR

REF.9 - P. N°16-B406  
DIAPHRAGM GASKET (ORANGE COLOR) /  
JUNTA DEL DIAFRAGMA (COLOR NARANJA)



Thickness / *Espesor* = 0.5 ±0.1 mm

REF.13 - P. N° 16-B407  
PUMP DIAPHRAGM GASKET (ORANGE COLOR) /  
JUNTA DE BOMBA DE DIAFRAGMA (COLOR NARANJA)



Thickness / *Espesor* = 0.8 ±0.1 mm

REF.10 - P. N°237-600  
DIAPHRAGM / DIAFRAGMA



Thickness / *Espesor* = 0.13 ±0.07

REF.14 - P. N°237-162  
PUMP DIAPHRAGM / BOMBA DE DIAFRAGMA

ALTERNATIVA



Thickness / *Espesor* = 0.10 ±0.063 mm

REF.11 - P. N° 91-A275  
DIAPHRAGM COVER / TAPA DEL DIAFRAGMA





Thickness / *Espesor* = 6.75 ±0.15 mm

REF.15 - P. N° 141-89  
PUMP COVER / TAPA DE LA BOMBA

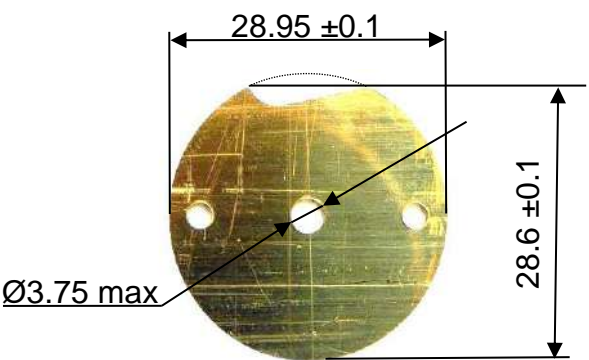
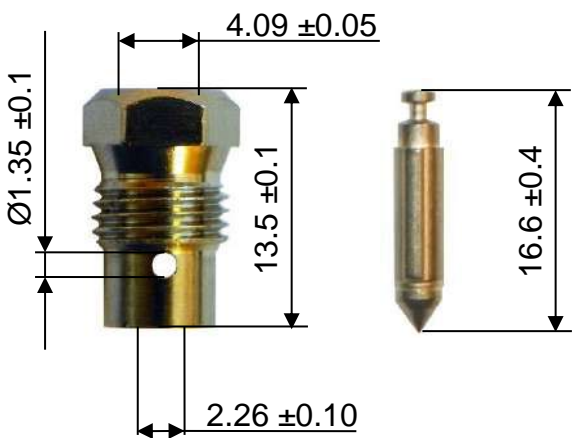

Thickness / *Espesor* = 12.5 ±0.15 mm

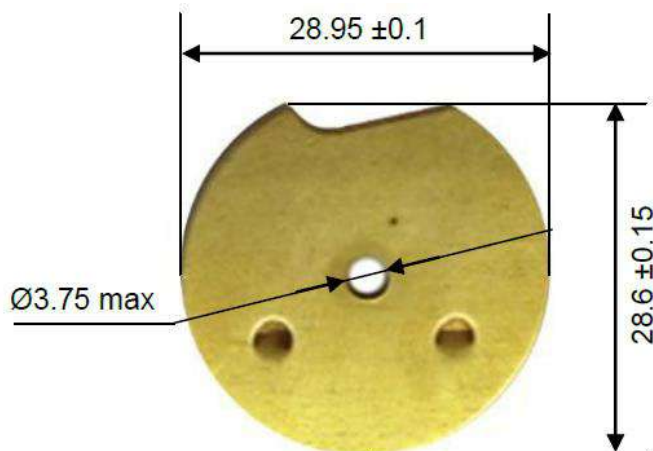
<p>REF.37 - P. Nº 14-A114 THROTTLE SHUTTER / CUERPO DE MARIPOSA</p>  <p>Thickness / <i>Espesor</i> = 0.81 ±0.1 mm</p>	<p>REF.27 - P. Nº 233-721P SEAT + NEEDLE / ASIENTO + AGUJA</p> 
<p>REF.21A - P. Nº 43-1029 NEEDLE LOW SPEED / AGUJA DE BAJA VELOCIDAD</p> 	<p>REF.30A - P. Nº 43-1030 NEEDLE HIGH SPEED / AGUJA DE ALTA VELOCIDAD</p> 
<p>ALTERNATIVE THROTTLE SHUTTER (made from production tooling) / CUERPO DE MARIPOSA ALTERNATIVO (fabricado con herramientas de producción)</p>	<p>ALTERNATIVE FUEL NEEDLE / AGUJA DE COMBUSTIBLE ALTERNATIVA</p>
<p>REF.37 - P. Nº 14-A114</p>  <p>Thickness / <i>Espesor</i> = 0.81 ±0.1 mm</p>	<p>REF.27 - P. Nº 233-721P</p> 