



FICHA DE HOMOLOGACIÓN DE CARBURADOR

Nº HOMOLOGACIÓN: E: 6 – M – 19



CATEGORÍA

JUNIOR - SENIOR

VALIDEZ  
HOMOLOGACIÓN

2019



## CARBURETTOR Tillotson HW-27A



PHOTO OF ADJUSTING SIDE



PHOTO OF INLET SIDE

Manufacturer

TILLOTSON LTD.

Make

TILLOTSON

Model

HW-27A

SECTION VIEW

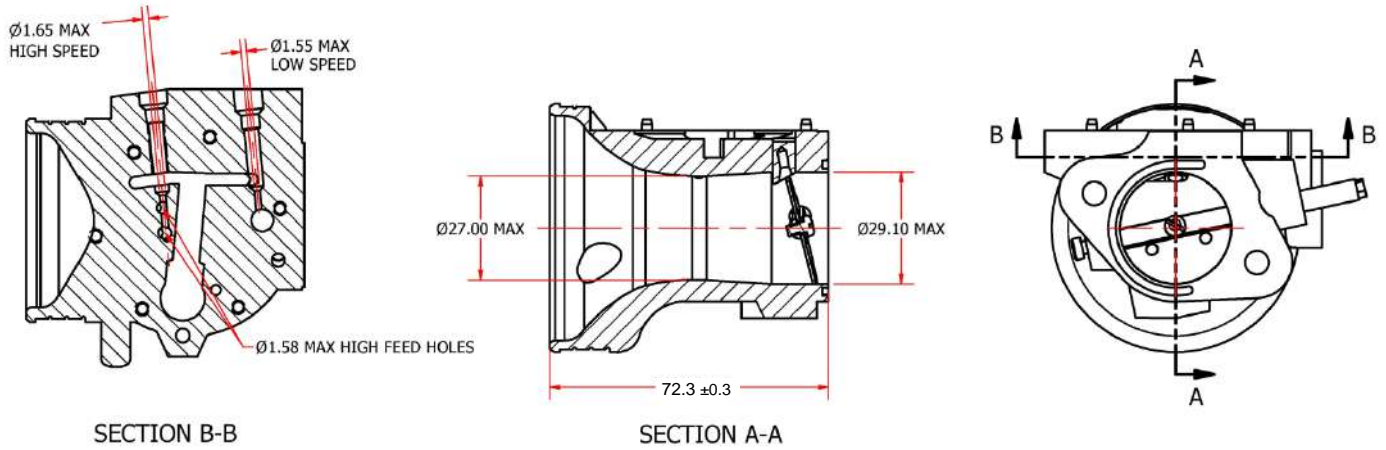

MARKING

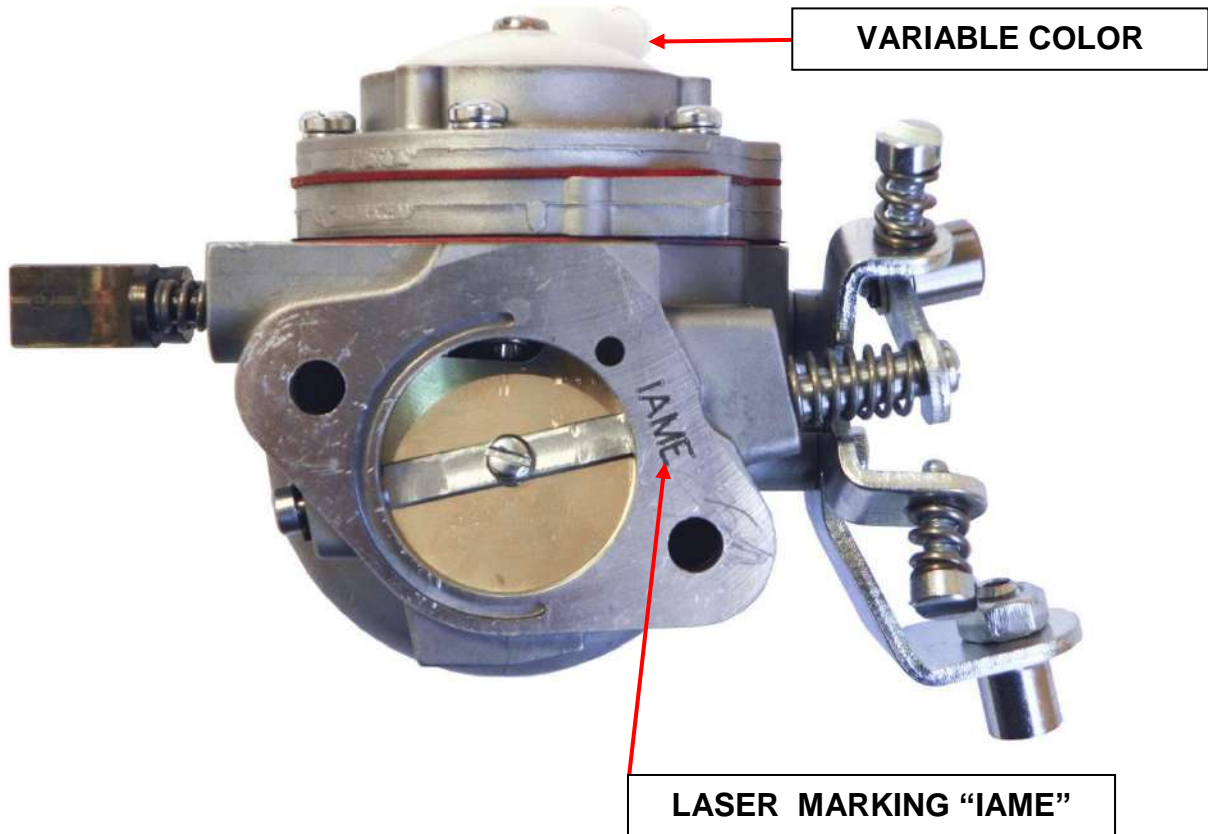

## CARBURETTOR DESCRIPTION AND SKETCH OF PARTS

HW-27A

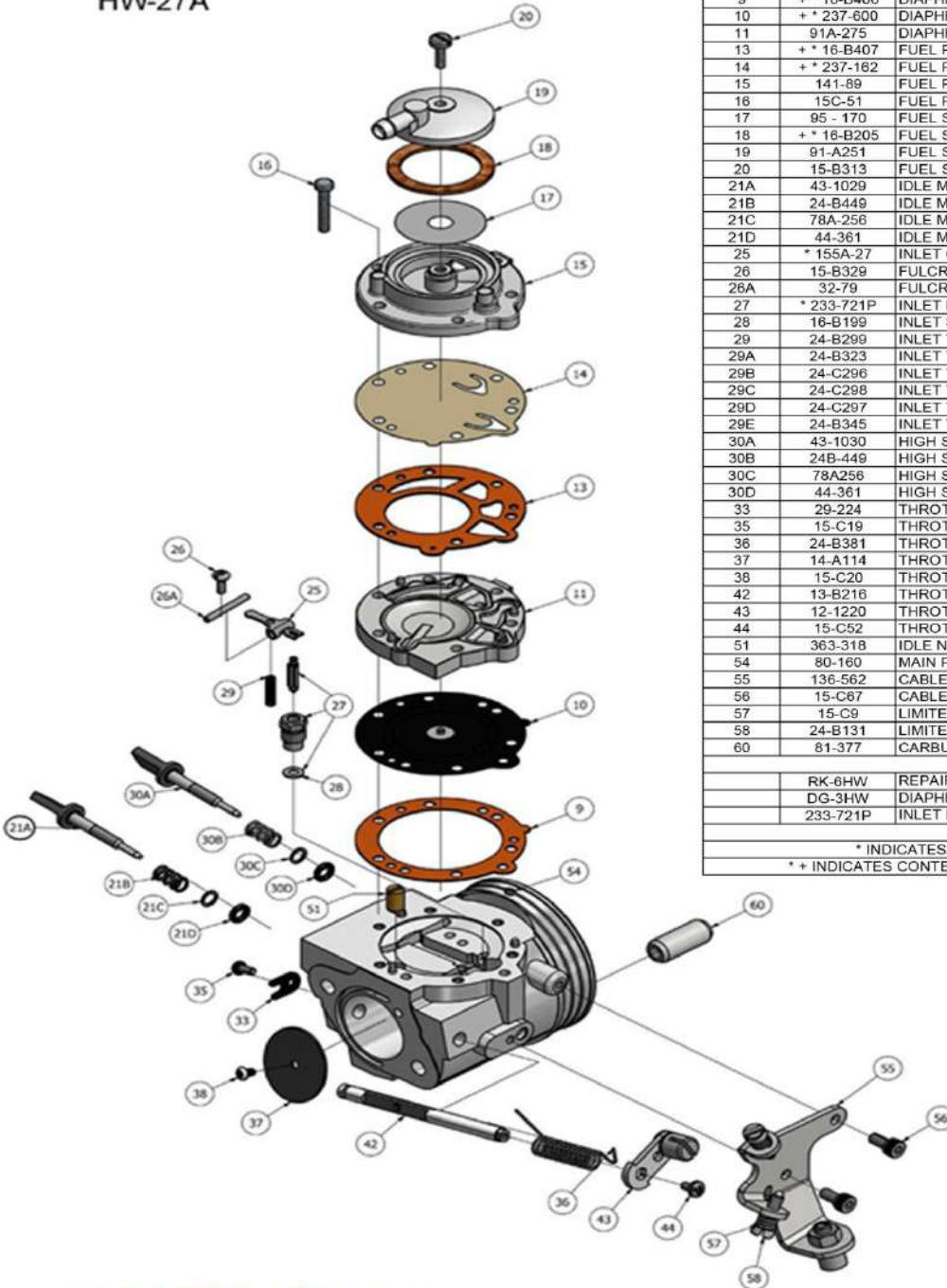

ITEM	PART NO:	DESCRIPTION	QTY
9	+ * 16-B406	DIAPHRAGM GASKET (ORANGE)	1
10	+ * 237-600	DIAPHRAGM	1
11	91A-275	DIAPHRAGM COVER	1
13	+ * 16-B407	FUEL PUMP GASKET (ORANGE)	1
14	+ * 237-162	FUEL PUMP DIAPHRAGM	1
15	141-89	FUEL PUMP BODY	1
16	15C-51	FUEL PUMP BODY SCREW	6
17	95 - 170	FUEL STRAINER SCREEN	1
18	+ * 16-B205	FUEL STRAINER COVER GASKET	1
19	91-A251	FUEL STRAINER COVER	1
20	15-B313	FUEL STRAINER COVER RETAINING SCREW	1
21A	43-1029	IDLE MIXTURE SCREW	1
21B	24-B449	IDLE MIXTURE SCREW SPRING	1
21C	78A-256	IDLE MIXTURE SCREW WASHER	1
21D	44-361	IDLE MIXTURE SCREW PACKING	1
25	* 155A-27	INLET CONTROL LEVER	1
26	15-B329	FULCRUM LEVER SCREW	1
26A	32-79	FULCRUM LEVER PIN	1
27	* 233-721P	INLET NEEDLE & SEAT SET	1
28	16-B199	INLET SEAT GASKET	1
29	24-B299	INLET TENSION SPRING (STD 37 grams)	1
29A	24-B323	INLET TENSION SPRING (26 grams)	1
29B	24-C296	INLET TENSION SPRING (31 grams)	1
29C	24-C298	INLET TENSION SPRING (42 grams)	1
29D	24-C297	INLET TENSION SPRING (46 grams)	1
29E	24-B345	INLET TENSION SPRING (48 grams)	1
30A	43-1030	HIGH SPEED MIXTURE SCREW	1
30B	24B-449	HIGH SPEED MIXTURE SCREW SPRING	1
30C	78A256	HIGH SPEED MIXTURE SCREW WASHER	1
30D	44-361	HIGH SPEED MIXTURE SCREW PACKING	1
33	29-224	THROTTLE SHAFT CLIP	1
35	15-C19	THROTTLE SHAFT CLIP RETAINING SCREW	1
36	24-B381	THROTTLE RETURN SPRING	1
37	14-A114	THROTTLE SHUTTER	1
38	15-C20	THROTTLE SHUTTER SCREW	1
42	13-B216	THROTTLE SHAFT	1
43	12-1220	THROTTLE LEVER ASSEMBLY	1
44	15-C52	THROTTLE LEVER RETAINING SCREW	1
51	363-318	IDLE NOZZLE	1
54	80-160	MAIN PLUG	2
55	136-562	CABLE BRACKET	1
56	15-C67	CABLE BRACKET RETAINING SCREW	2
57	15-C9	LIMITER SCREW	2
58	24-B131	LIMITER SPRING	2
60	81-377	CARBURETTOR MOUNTING NUT	2
RK-6HW		REPAIR KIT	
DG-3HW		DIAPHRAGM & GASKET (STANDARD)	
233-721P		INLET NEEDLE & SEAT SET	
* INDICATES CONTENTS OF REPAIR KIT			
* + INDICATES CONTENTS OF DIAPHRAGM & GASKET SET			

**Tillotson**  
RACING

Clash Industrial Estate - Tralee - Ireland  
www.tillotson-racing.com

**IQME**



PARTS OF CARBURETTOR

REF.9 - P. N°16-B406  
DIAPHRAGM GASKET (ORANGE COLOR)



Thickness =  $0.5 \pm 0.1$  mm

REF.13 - P. N° 16-B407  
PUMP DIAPHRAGM GASKET (ORANGE COLOR)



Thickness =  $0.8 \pm 0.1$  mm

REF.10 - P. N°237-600  
DIAPHRAGM



Thickness =  $0.13 \pm 0.07$  mm

REF.14 - P. N°237-162  
PUMP DIAPHRAGM



Thickness =  $0.10 \pm 0.063$  mm

REF.11 - P. N° 91-A275  
DIAPHRAGM COVER





Thickness =  $6.75 \pm 0.15$  mm

REF.15 - P. N° 141-89  
PUMP COVER

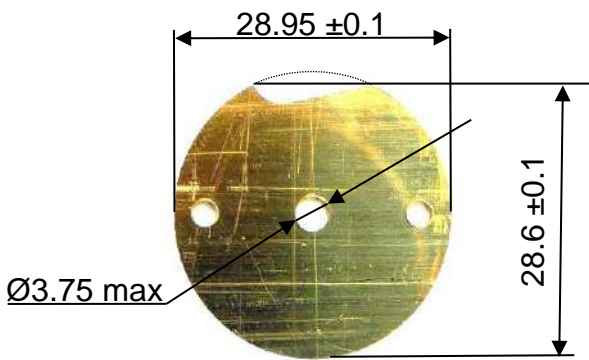
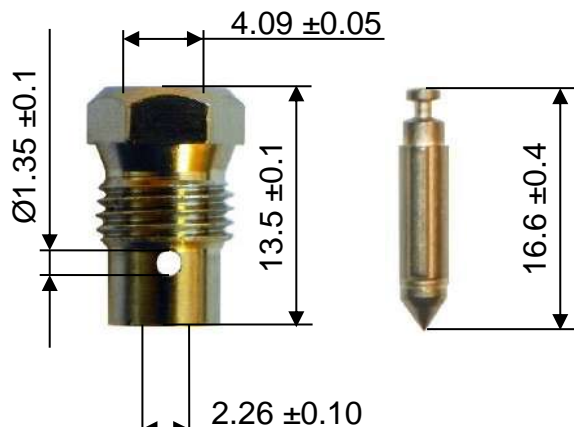

Thickness =  $12.5 \pm 0.15$  mm

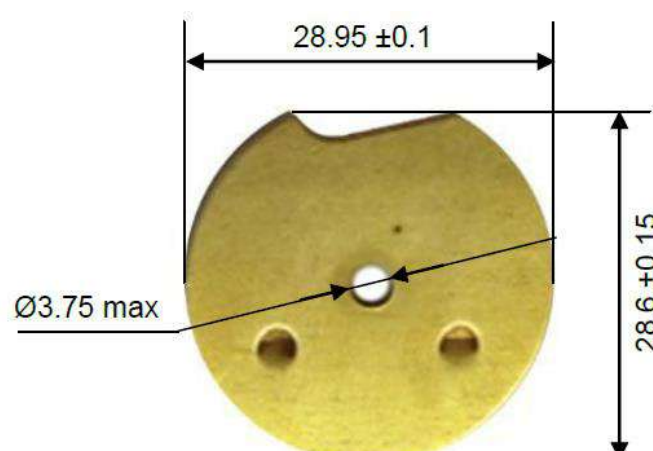
<p><b>REF.37 - P. N° 14-A114 THROTTLE SHUTTER</b></p>  <p>Thickness = 0.81 ±0.1 mm</p>	<p><b>REF.27 - P. N° 233-721P SEAT + NEEDLE</b></p> 
<p><b>REF.21A - P. N° 43-1029 NEEDLE LOW SPEED</b></p> 	<p><b>REF.30A - P. N° 43-1030 NEEDLE HIGH SPEED</b></p> 
<p><b>ALTERNATIVE THROTTLE SHUTTER</b> (made from production tooling)</p>	<p><b>ALTERNATIVE FUEL NEEDLE</b></p>
<p><b>REF.37 - P. N° 14-A114</b></p>  <p>Thickness = 0.81 ±0.1 mm</p>	<p><b>REF.27 - P. N° 233-721P</b></p> 